

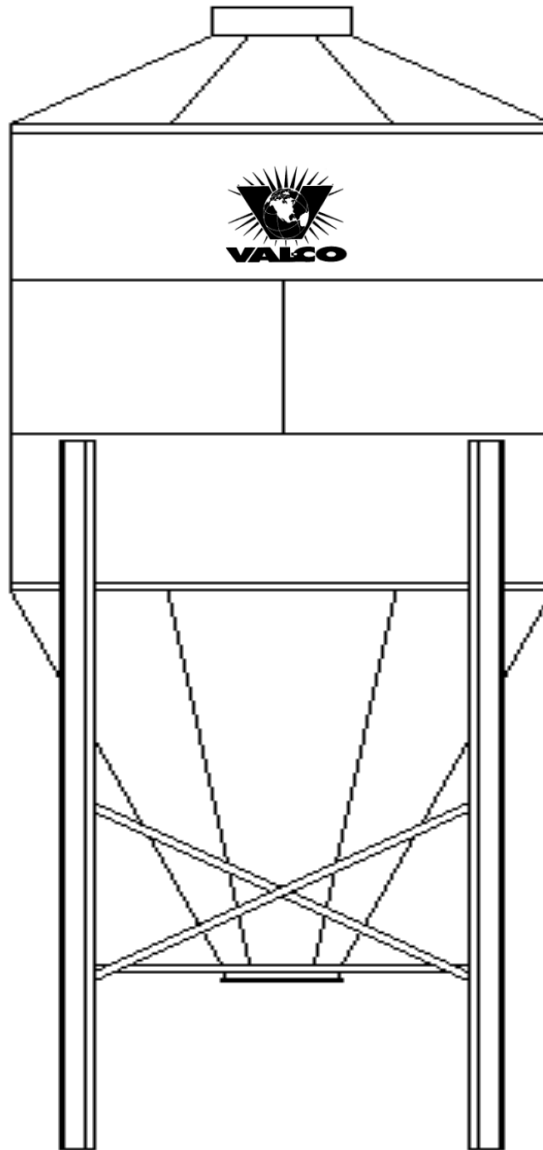

7' BULK FEED BIN

MODEL 507

Installation Manual





INTENTIONALLY BLANK



CONTENTS

Warranty.....	4-6
Introduction.....	7
Site Selection.....	7
General Information.....	8
Safety Symbols – Warning Labels.....	9
7’ Feed Bin Hardware Parts.....	10
Tools Required.....	10
7’ (2.13m) Feed Bin Specifications.....	11
Foundation and Anchoring Specifications.....	12
7’ Diameter Bin Dimensions.....	13
7’ Feed Bin Overview.....	14
Overview continued - Special bracing for 178” Bin Leg.....	15
Hardware Assembly Summary.....	16
Corrugated Hopper Assembly/Caulking Instructions.....	17-18
Taper Hopper and Collar Assembly.....	19
Roof Deck and Lid Collar Assembly.....	20
Leg and Tank Assembly.....	21
Leg and Brace Assembly.....	22
Roof Ladder Assembly.....	23
Side Ladder Assembly.....	24
Erecting the Bin - Bin Lifting Kit Assembly.....	25-26
Appendix - 1 - 7 Ft Feed Bin Parts List.....	27-30
Appendix - 2 - 7 ft Feed Bin Accessories Parts List.....	31
Appendix - 3 - Bin 16” Opening Attachments.....	32
Appendix - 4 - Auger Length Needed.....	33
Appendix - 5 - Way-Back Lid Overview.....	34
Appendix - 6 - Exploded Way-Back Lid Assembly Drawing.....	35
Appendix - 7 - Way-Back Lid Parts List.....	36
Appendix - 8 - Way-Back Lid Cord Containment Bracket and Retainer Parts List.....	37
Appendix - 9 - Tru-Lok Add-On Opener Option - Overview.....	38
Appendix - 10 - Tru-Lok Part Drawings and Parts List.....	39
Appendix - 11 - Ladder Parts Drawing and Parts List.....	40
Appendix - 12 - Ladder Cage Option and Parts List.....	41
Appendix - 13 - Pneumatic Fill Option Overview and Parts List.....	42
Appendix - 14 - Customer Service.....	43



Warranty

VAL PRODUCTS, INC. WARRANTIES

VAL-CO™ MANUFACTURED PRODUCTS OTHER THAN EXTENDED WARRANTY PRODUCTS

Val Products, Inc. (Val Products) warrants to the original purchaser that Val Products' manufactured products (other than the products subject to an extended warranty set forth below) will be free of defects in material and workmanship for a period of one (1) year from and after the date of original purchase and when used in a usual and customary fashion. If Val Products is notified that such a defect exists within one year of the original purchase date and, upon inspection, agrees that the product is defective, Val Products will, at its option, (a) repair or replace (FOB Val Products' plant) the defective product, or (b) refund to the original purchaser the original purchase price paid for the defective product less any installation, shipping, or other charges associated with the original purchase. All defective products must be returned to a Val Products designated location for evaluation. Val Products' determination as to whether the product is defective is final. See the General Conditions and Limitations set forth below.

NIPPLE DRINKERS EXTENDED WARRANTY

Val Products, Inc. (Val Products) agrees to the following extended warranty with respect to VR Series and VL Series Nipple Drinkers manufactured by Val Products: VR Series and VL Series Nipple Drinkers that prove to be defective in workmanship or material and become unusable within a period of five (5) years from and after the date of original purchase will be repaired or replaced, at Val Products' option, at no charge (excluding labor of removal and installation), FOB Val Products' plant. VR Series and VL Series Nipple Drinkers which prove to be defective in workmanship or material and become unusable after five (5) years but within ten (10) years of the date of original purchase will be repaired or replaced, at Val Products' option, at a pro rated cost basis (excluding labor of removal and installation) to the original purchaser, FOB Val Products' plant, on the following basis: Year six (6), customer pays 50% of the current price, year seven (7), customer pays 60% of the current price, year eight (8), customer pays 70% of the current price, year nine (9), customer pays 80% of the current price, and year ten (10), customer pays 90% of the current price. All defective Nipple Drinkers must be returned to a Val Products' designated location for evaluation. Val Products' determination as to whether the product is defective and unusable is final. See the General Conditions and Limitations set forth below.

FIBERGLASS FAN HOUSINGS EXTENDED WARRANTY

Val Products, Inc. (Val Products) agrees to the following extended warranty with respect to the fiberglass fan housings manufactured by Val Products on VAL-CO™ PMC Power Miser 12", 16", 21", 24", 36", 48", and 50" Fiberglass Fans that prove to be defective in workmanship or material and become unusable over the life of the structure where the VAL-CO™ Fiberglass Fan was originally installed after original purchase, provided that the fan has remained undisturbed in its original installation location, will be repaired or replaced, at Val Products' option, at no charge (excluding labor of removal and installation and shipping), FOB Val Products' plant. All defective fan housings must be returned to a Val Products' designated location for evaluation. Val Products' determination as to whether the product is defective and unusable is final. See the General Conditions and Limitations set forth below.



FIBERGLASS FAN MOTORS EXTENDED WARRANTY

Val Products, Inc. (Val Products) agrees to the following extended warranty with respect to the fiberglass fan motors included as original equipment on VAL-CO™ PMC Power Miser 12", 16", 21", and 24" Fiberglass Fans manufactured by Val Products that prove to be defective in workmanship or material and become unusable within a period of two (2) years from and after the date of original purchase will be repaired or replaced, at Val Products' option, at no charge (excluding labor of removal and installation and shipping), FOB Val Products' plant. All defective fan motors must be returned to a Val Products' designated location for evaluation. Val Products' determination as to whether the product is defective and unusable is final. See the General Conditions and Limitations set forth below.

General Conditions and Limitations Applicable to All Val Products, Inc. (Val Products) Warranties, Including Extended Warranties

1. The Product must be installed and operated in accordance with instructions published by Val Products or the warranty will be void.
2. Warranty will be void if all components of the product or system are not original equipment supplied by the manufacturer.
3. Products not manufactured by Val Products and supplied by outside manufacturers (such as, but not limited to, certain electrical motors, certain controls, gas valves, etc.) are warranted separately by the respective manufacturer and only to the extent of the manufacturer's warranty.
4. Warranty applies only to products used in applications as originally intended by Val Products – other applications in industry or commerce are not covered by the Warranty. Val Products' products are expressly not designed or authorized for use in any applications where intended to sustain or support human life or any other application where the failure of the product could result in personal injury or death.
5. Malfunctions resulting from misuse, abuse, mismanagement, negligence, alteration, accident, lack of proper maintenance, lightening strikes, electrical power surges, or electrical power interruption shall not be considered defects under the Warranty. Corrosion, material deterioration and/or equipment malfunction caused by or consistent with the excessive additions of chemicals, minerals, sediments or other foreign elements with the product shall not be considered defects under the Warranty.
6. VAL PRODUCTS WILL NOT, UNDER ANY CIRCUMSTANCES, BE LIABLE FOR ANY KIND OF SPECIAL, INCIDENTAL, CONSEQUENTIAL, OR CONTINGENT DAMAGES INCLUDING, BUT NOT LIMITED TO, LOST OR DAMAGED PRODUCT, GOODS OR LIVESTOCK, COSTS OF TRANSPORTATION, LOST SALES, LOST ORDERS, LOST INCOME, INCREASED OVERHEAD, LABOR AND INCIDENTAL COSTS AND OPERATIONAL INEFFICIENCIES. IN NO EVENT SHALL THE WARRANTY LIABILITY EXCEED THE INVOICED PRICE OF THE PRODUCT TO THE ORIGINAL PURCHASER.



7. THE WARRANTIES SET FORTH ABOVE CONSTITUTE VAL PRODUCTS' ENTIRE AND SOLE WARRANTY. VAL PRODUCTS EXPRESSLY DISCLAIMS ANY AND ALL OTHER WARRANTIES INCLUDING, BUT NOT LIMITED TO, ANY AND ALL OTHER EXPRESS OR IMPLIED WARRANTIES AS TO THE MERCHANTABILITY, FITNESS FOR A PARTICULAR PURPOSE OR USE, DESCRIPTION OF QUALITY OF THE PRODUCT FURNISHED, AND ANY OTHER WARRANTY ARISING BY OPERATION OF LAW, CUSTOM OR USAGE.
8. Val Products denies any authorization of any distributor, dealer, agent, or employee to modify, extend, or otherwise alter the conditions of any warranty in addition to, or in lieu of, those conditions and authorized in writing by an officer of Val Products. Val Products reserves the right to change or delete models, or change specifications at any time without notice or obligation to improve previous products.



Introduction

This manual covers the assembly instructions for the 7' Feed Bin with parts lists. Bin accessories and options have been added to the appendixes for your convenience.

Features

- Weather tight die formed roof
- Reinforced ribs at the seams for added strength and ease of assembly
- Warp resistant top lid closes tight to keep out moisture and offers smooth operating openers
- Bin bolts have a built in weather seal
- Drip edge keeps water away from the taper hopper and unloading boot
- Taper Hoppers are offset to allow smooth feed flow
- Bin sheets are made of heavy gauge G-90 galvanized steel with 2-2/3" wide by 1/2" deep corrugation
- Legs are die formed with a sturdy bracing system for structural support.
- High strength bolts are used throughout

Site Selection

The success of assembling your new bulk bin begins with the ground you start on and the foundation you lay. The selected site must be firm, level ground with good water drainage and a soil bearing capacity of 3500 lbs. per sq. ft. Check with your local soil engineer if you have any questions. When you have determined that the soil is acceptable, you should also consider the following factors: accessibility of feed handling equipment, space for future growth and the absence of overhead obstructions such as power lines or tree branches.



General Information

- Read all safety information, instructions and illustrations before starting to assemble your new bulk bin.
Please review the complete assembly manual twice before starting and be sure to check your shipment with the packing list for any shortages. Please report shortages promptly.
- Metric measurements are shown in millimeters and in parenthesis throughout the manual. Example: 13” (330mm)
- The terms horizontal and vertical refer to the bin in a standing position.
- Instructions for optional bin accessories are packaged with the components.
- To help decide which is the top and bottom of corrugated hoppers, a hole spacing of 3.125” (79mm) is used at the top of all extension hoppers and at the bottom of all main hoppers.
- Vertical seams must be staggered on all hopper rings. On 9’ x 5 or 6 ring and 7’ x 5 or 6 ring bins align leg holes on bottom two main hopper rings to accommodate longer legs.
- Taper hopper vertical seams and boot collar seam use truss head bin bolts with the head always on the inside of the bin to allow for better feed flow.
- Corrugated hoppers and roof deck seams use hex head bin bolts with the head to the outside except to fasten legs to corrugation where the bolt head goes to the inside.
- Tighten all bin bolts from the nut side to help reduce the possibility of damaging the rubber seal on bin bolts. Do not allow the bolt heads to spin when tightening.
- When assembling corrugation sheets, use a drift pin to help align holes and always overlap sheets in the same direction. Finger tighten nuts until the next ring is assembled.
- Remove protective paper from decal before raising bin. Paper may be difficult to remove if exposed to warm sunlight for several hours.



Our concern is for your safety. The safety warnings are included in this manual as a guide to help and encourage the safe operation of your feeding equipment. It is your responsibility to evaluate the hazards of each operation and implement the safest method of protecting yourself as owner and/or operator.

Safety Symbols - Warning Labels



= NOTE - take notice this may help you!



= IMPORTANT INFORMATION - be sure to read!



= CHECK - the details of all requirements, processes or procedures of instructions listed.



= WARNING - The safety alert symbol is always used on warning signs that involve your safety. Anytime you see this symbol heed the warning it identifies. This symbol may be used in conjunction with other symbols.



= DANGER - imminent hazard, if ignored serious injury or death WILL occur.





= WARNING - probable hazard, if ignored serious injury or death COULD occur.



= CAUTION - potential hazard, if ignored minor or moderate injury MAY occur.

- Avoid any alterations to the equipment. Such alterations may produce a very dangerous situation where serious injury or death may occur.
- Keep all safety guards on equipment
- Ground all electrical equipment. Do not bypass electrical safety equipment. Make sure electrical equipment is properly installed and grounded by a qualified electrician.
- Wear a hard hat during construction
- Order and attach warning symbols to danger areas that are not already noted
- Do not enter bin during operation or at any time without proper safety precautions.

This Label MUST be present on the inside of the roof lid. Contact your distributor for a free replacement if missing.

 DANGER	
YOU CAN SUFFOCATE UNDER MATERIAL IN THIS TANK	
	
FLOWING MATERIAL TRAPS AND SUFFOCATES	CRUSTED MATERIAL COLLAPSES AND SUFFOCATES
NEVER ENTER THIS TANK DURING LOADING AND UNLOADING	
AT OTHER TIMES ENTER TANK ONLY IF YOU	
<ol style="list-style-type: none"> 1. SHUT OFF AND LOCK OUT ALL POWER. 2. USE A SAFETY HARNESS AND SAFETY LINE. 3. WEAR PROPER BREATHING EQUIPMENT. 4. AVOID THE CENTER OF THE TANK. 5. STATION PEOPLE TO HELP OUTSIDE THE TANK. 	
<small>500443</small>	

9' Feed Bin Hardware Parts



Check all parts with each packing included with each carton of product or the parts list included in this manual at Appendix 1 on pages 26-29 before starting assembly. Report any shortages immediately to your supplier.



Save all cartons until bin is completed.

Hardware List

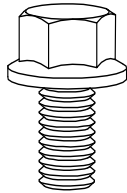

501442 - 5/16" x 1"
Flanged Hex Bin Bolt

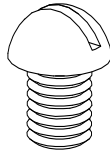

501440 - 5/16" x 3/4"
Truss Bin Bolt

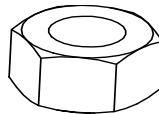

010603 - 5/16
Hex Nut

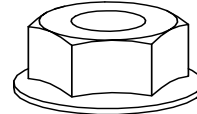

501441 - 5/16"
Flange Nut

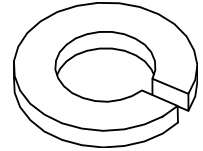

010253 - 3/8"
Lockwasher

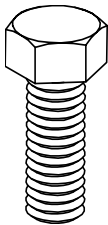

010664 - 3/8" X 1"
Hex Bolt

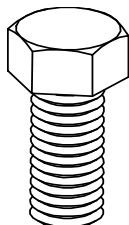

012240 - 7/16" x 1"
Hex Bolt

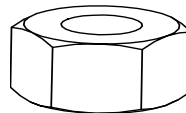

011115 - 3/8"
Hex Nut

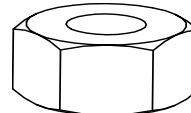

011116 - 7/16"
Hex Nut

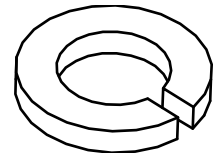

010254 - 7/16"
Lockwasher

Tools Required

Below is a list of tools required to assemble your new bin. The use of an electric or air impact wrench will greatly reduce your assembly time.

- Open or Box End Wrenches (1/2", 9/16", 5/8", 11/16")
- Socket Set with Speed Wrench or Impact
- Hammer or Rubber Mallet
- Large Screwdriver
- 12" Drift Punches
- Nail Apron for convenience



Be careful when using power equipment not to over-torque the fasteners.



7' (2.13 m) Feed Bin Specifications

FEED BIN DIAMETER	NUMBER OF RINGS	APPROXIMATE CAPACITY (40#/CUBIC FT.)					FILL HEIGHT	
		2000 LB. TONS	METRIC TONS	CUBIC FEET	CUBIC METERS	BUSHELS	FEET	METERS
7' DIAMETER 60° Taper Hopper 40° Roof 16" Opening	1	4.72	4.28	236.1	6.69	190	14' 7"	4.45
	2	6.77	6.15	338.7	9.59	272	17' 3"	5.26
	3	8.83	8.01	441.3	12.50	355	19' 11"	6.07
	4	10.88	9.87	543.8	15.40	437	22' 7"	6.88
	5	12.93	11.73	646.4	18.30	519	25' 3"	7.70
	6	14.98	13.59	748.9	21.21	602	27' 11"	8.51



- All 16" opening bins include VAL-CO™'s exclusive 2-piece boot collar
- Ladder safety cages are available
- All bins are designed for the storage of FREE-FLOWING materials only



Soybean Meal, meat scraps and certain other materials are NOT considered FREE-FLOWING and should NOT be stored in these bins.



Foundation and Anchoring Specifications



To avoid cable hanging over edge of slab, place a PVC tube thru slab before pouring to drive ground rod thru.

After selecting the best site for your new bin and making sure the soil has the required 3500 pounds per square foot (psf), you are now ready to begin your foundation. It is extremely important that your bin has a firm and level foundation. The concrete used for this must have a minimum compression rate of 3000 lbs. per square inch at 28 days. The pad must be smooth and meet the dimensions listed below. It is imperative that it is poured both square and level. When laying out the bolt locations, it is very important the bin maintains squareness. Be sure to check all (3) diagonal measurements and hold the same distance between holes *as shown below in Figure 1*. The "L" shaped anchor bolt *shown in Figure 2 below* can be purchased from local retailers. When using the optional anchor bolts, *shown in Figure 3 below*, holes can be drilled after concrete has set. However; you must use the same dimensions as shown below to assure the bin maintains squareness. Note: Locating anchor bolt holes by using the assembled bin legs does not assure the bin will be set squarely and can result in damage to equipment and/or personal injury.

FIGURE 1

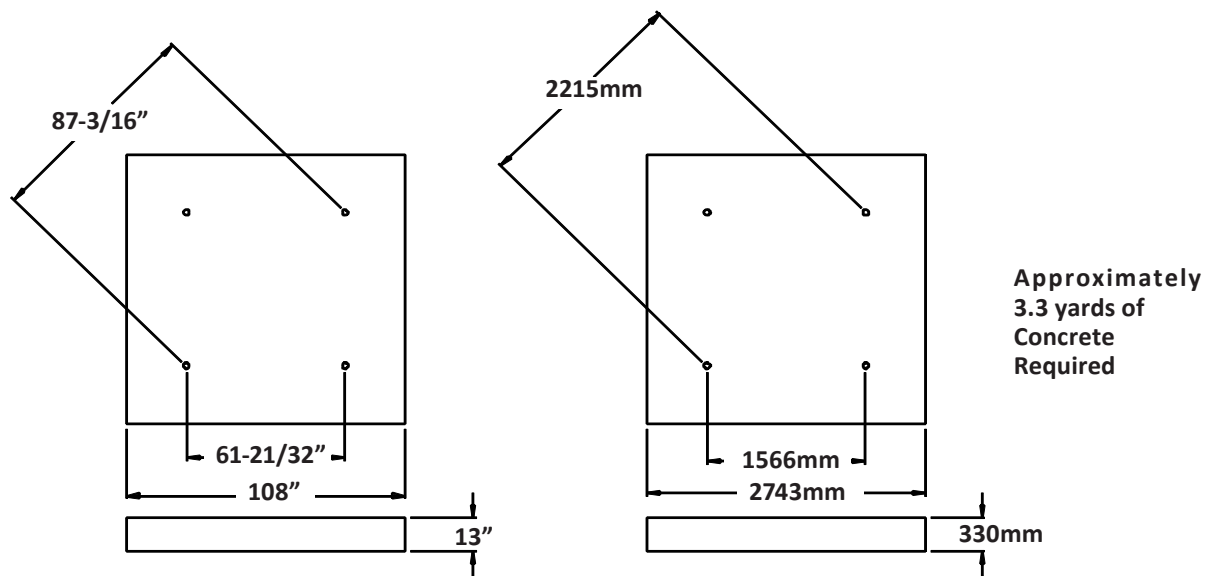

FIGURE 2

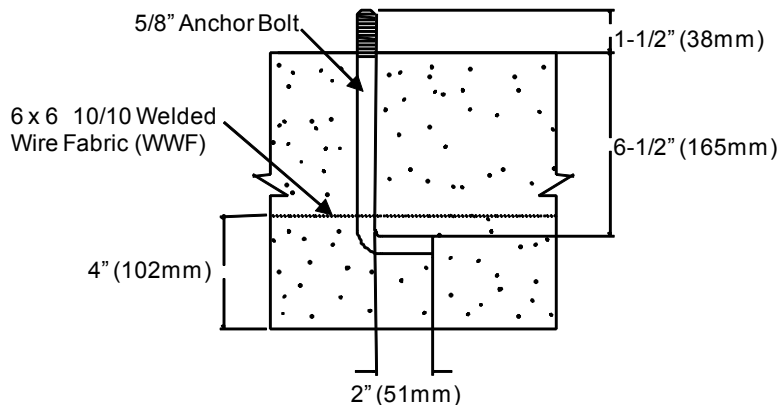
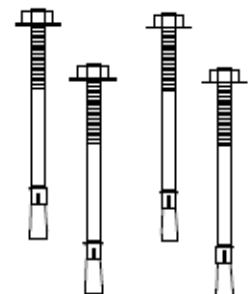

FIGURE 3

Optional style anchor bolts as shown here can be supplied by VAL-CO™.

Order kit #500220 for 7' bins.





7' Diameter Bin Dimensions

FIGURE 4

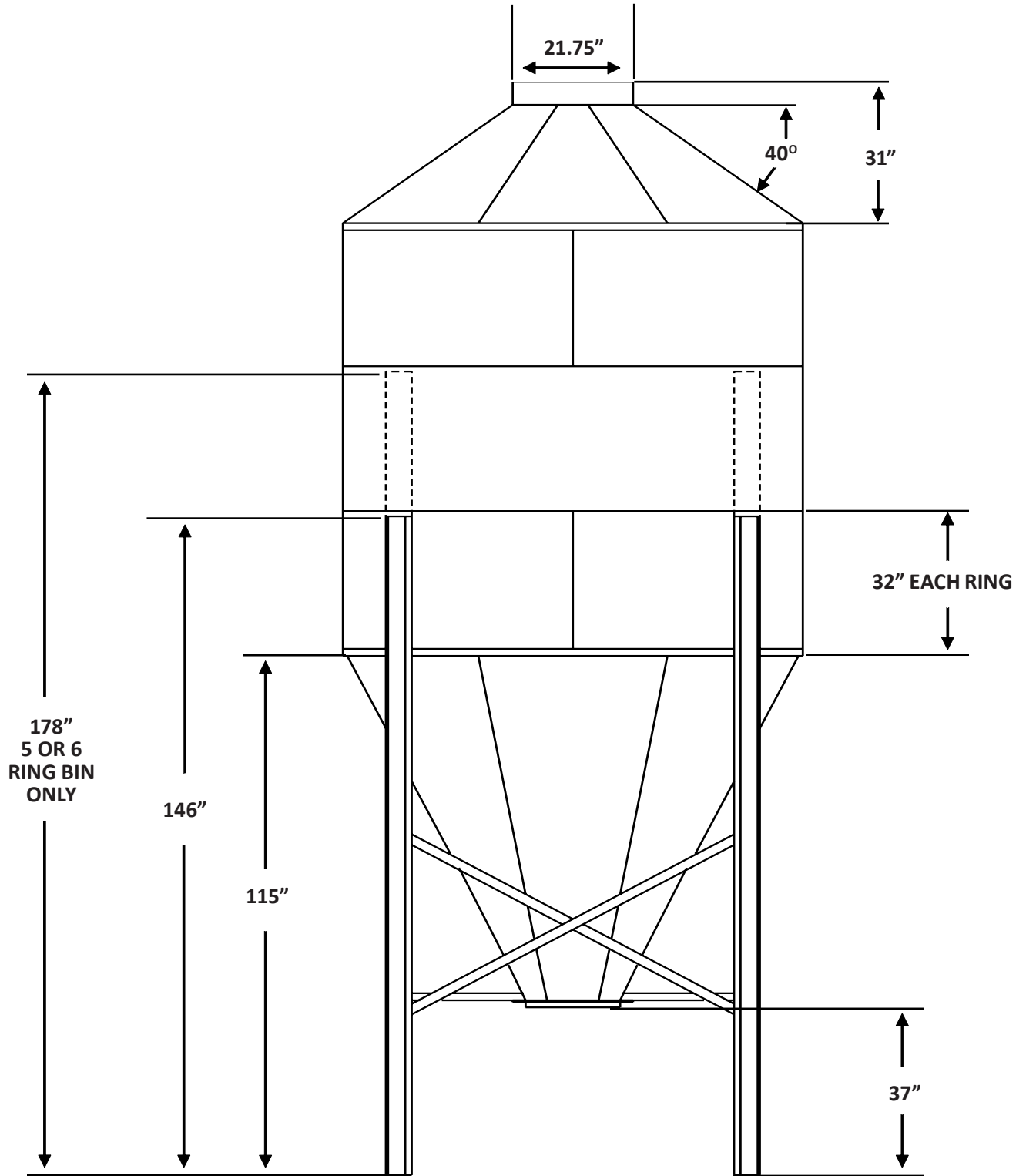

FIGURE 5

7' Feed Bin Overview

CORROGATED HOPPER SHEETS

1 RING BIN

507046 18ga Main - (1)
507047 18ga Main w/Decal - (1)

2 RING BIN

507046 18ga Main - (2)
507007 20ga Extension - (1)
507008 20ga Ext. w/Decal - (1)

3 RING BIN

507046 18ga Main - (2)
507007 20ga Extension - (3)
507008 20ga Ext. w/Decal - (1)

4 RING BIN

507046 18ga Main - (2)
507007 20ga Extension - (5)
507008 20ga Ext. w/Decal - (1)

5 RING BIN

507046 18ga Main - (2)
507016 18ga Main Ext. - (2)
507007 20ga Extension - (5)
507008 20ga Ext. w/Decal - (1)

6 RING BIN

507046 18ga Main - (2)
507016 18ga Main Ext. - (2)
507007 20ga Extension - (7)
507008 20ga Ext. w/Decal - (1)

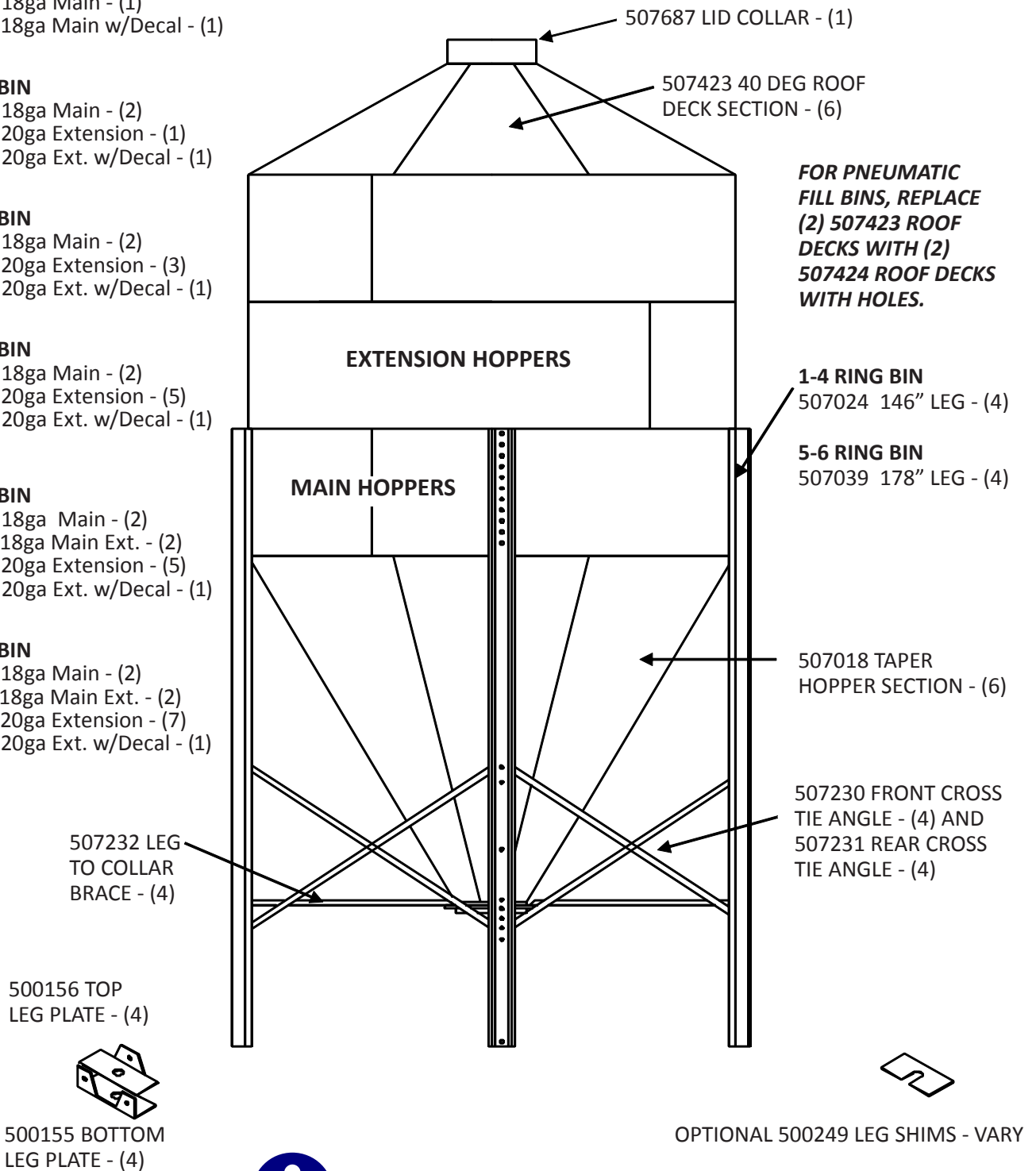

5 - 6 RING BINS REQUIRE SPECIAL BRACING AS SHOWN ON NEXT PAGE.



Overview Continued - Special Bracing For 178" Bin Legs

FIGURE 6

Leg Brace assembly is in detail on page 22.

Bracing for 7' x 5 or 6 ring Bins:

- (1) 507074 "X" Brace Bundle
- (1) 507073 Brace Tie Bundle
- (1) 509167 Special Brace Hardware. Bag

Use 7/16" x 1" hex bolts, nuts and lockwashers in 507161 hardware bag from 507160 Basic hardware carton to fasten cross braces to legs. Use 5/16 x 1" hex bin bolts and nuts in this bag to attach "X" braces to cross braces.

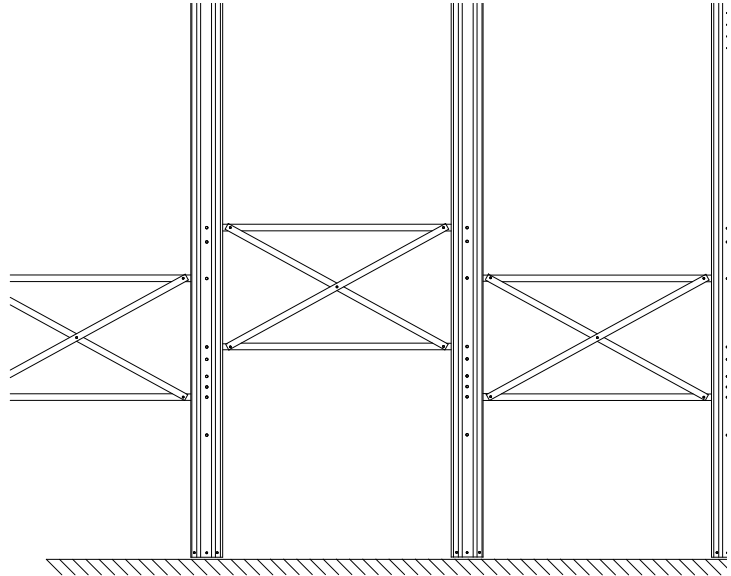

Hardware Assembly Summary

This illustration shows the type of fasteners, placement and position of caulking. This illustration can be used as a quick reference when assembling your bin. Refer to the step-by-step instructions for complete assembly details.

● = Caulking Bead (*IT IS RECOMMENDED THAT YOU USE THE CAULKING PROCEDURE ON PAGE 17.*)

FIGURE 7

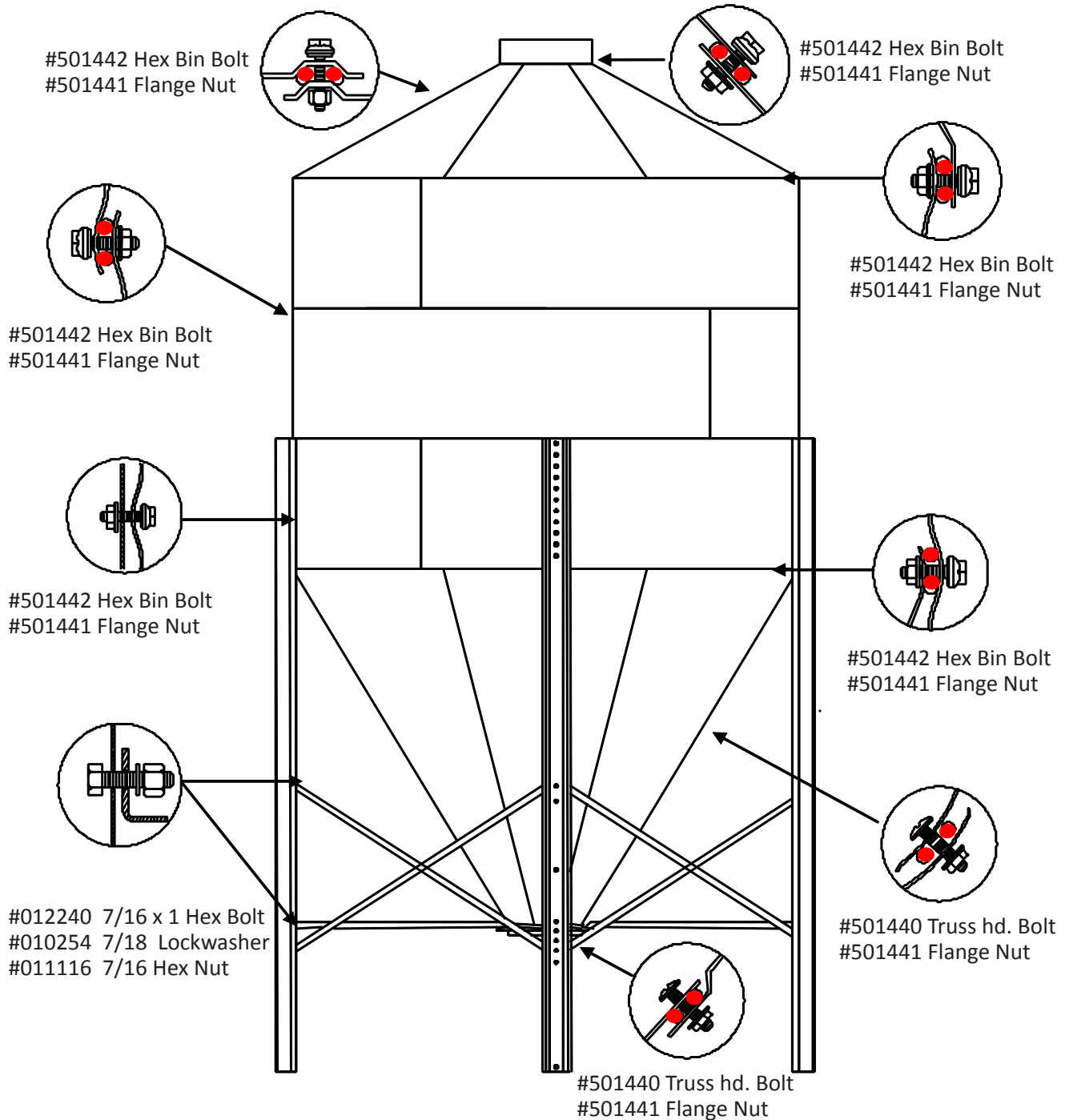



Corrugated Hopper Assembly / Caulking Instructions

Begin by determining assembly method. Val-Co™ bins may be assembled either horizontally or vertically. **VERTICAL** assembly for 7 Ft bins can be accomplished using the Val-Co™ Bin Lifting Kit #500578 as described on page 26. Processes are basically the same in both methods of assembly. (Vertical assembly is recommended for 12 ft bins.)

1. Identify the 2 heaviest corrugated hopper sheets by either the ID tag, (which are color coded), or by the extra row of vertical holes and the bottom row of holes being spaced 3 1/8" apart as shown in Figure 8 to the right.

COLOR CODE	HOPPER THICKNESS
GREEN	16 GA. HOPPER
RED	18 GA. HOPPER
BLACK	20 GA. HOPPER

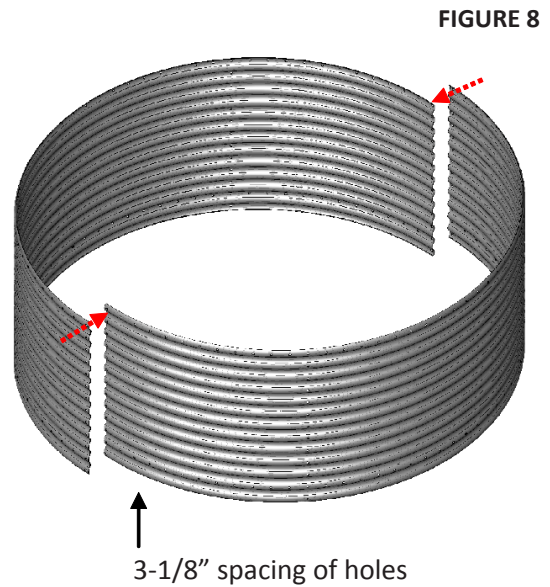

FIGURE 8

2. Apply the caulking putty to the inside of the hopper sheets, (where they join and form a seam), along side the holes to form a tight seal as shown in Figure 9 to the right.
3. Place the caulked end over the un-caulked end of each adjacent hopper sheet. (As the RED arrows show in the drawing at the top right of this page.)



Be sure caulking forms a good seal around the holes and seam to prevent leaking.

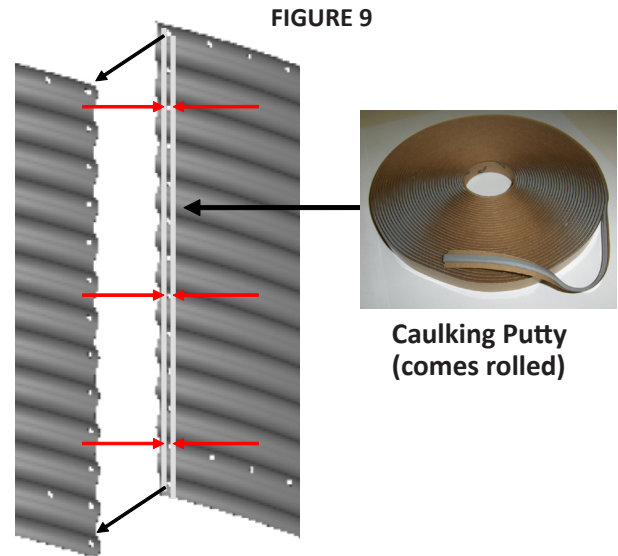

FIGURE 9

Caulking Putty (comes rolled)

4. Assemble ends with #501442 bin bolts and #501441 Flange Nuts. Continue inserting Bin Bolts and Flanged Nuts to all the holes along the vertical seam as you assemble the ring. **Do not tighten until both sheets of ring are assembled.**

#501442 Hex Bin Bolt (Flanged) on outside of bin

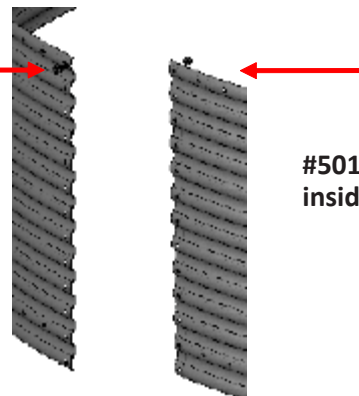
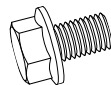

FIGURE 10

#501441 Flanged Nut on inside of bin



5. Refer to parts list on **page 14** to determine the next sheets required to build additional rings.
6. Place (1) 2nd ring hopper on top of the assembled 1st ring **making sure the 2nd ring hopper sheet ends are at the center of the 1st ring hopper sheets and holes align, as illustrated to the right in Figure 11.** Use the **#501442 Hex Bin Bolt and the #501441 Flanged Nuts in each hole to attach.** On 5 and 6 ring bins you will need to align leg holes with bottom ring leg holes.



Be sure to caulk all seams along both sides of the holes to form a good seal to prevent leaking! (As illustrated on page 17.)

FIGURE 11

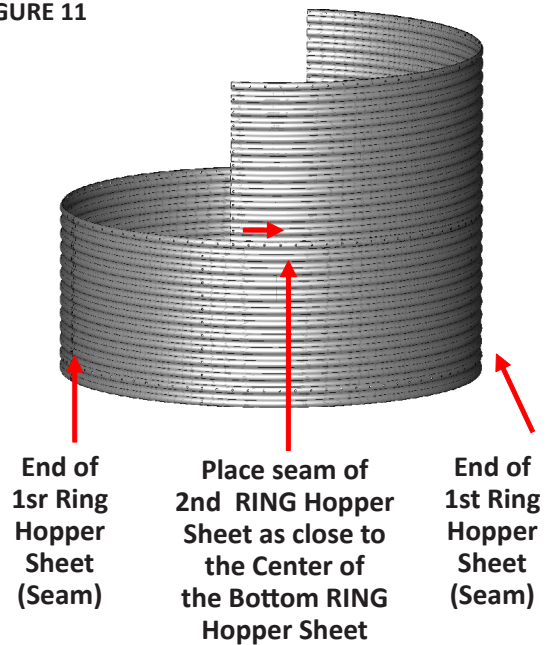
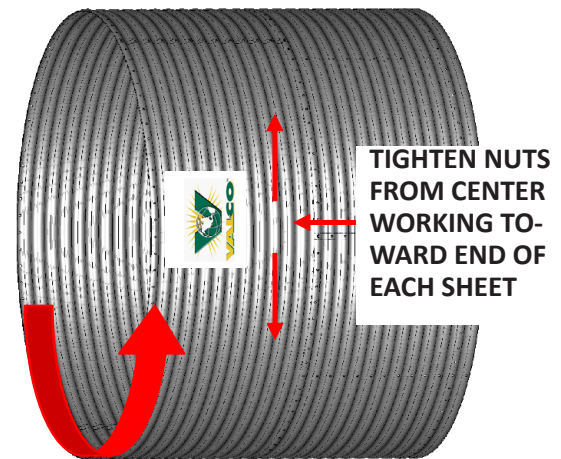

FIGURE 12

7. After completing the second ring you should lay assembly on its side so hoppers can be rolled easily to help make remaining assembly easier *as shown in Figure 12.*
8. Tighten horizontal seams by starting in center of hopper sheet and working toward ends *as shown with red arrows in Figure 12.*



- *Make sure you have aligned the corner hole where the (2) hopper sheets meet first for easiest assembly.*
- *Remember to complete entire ring before tightening nuts.*

FIGURE 13

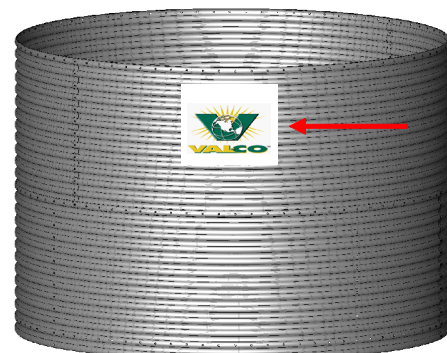

When all hopper sheets are assembled you should have the heaviest corrugation on the bottom and the decaled sheet on top.



Taper Hopper and Collar Assembly



Before assembling taper hopper sections to corrugated hoppers you must apply the caulking as previously instructed on page 17, to assure a watertight seal.

1. Begin caulking around the inside of the bottom row of holes on the bottom ring of corrugated hopper sheets .
2. Caulk taper hopper sheets along the vertical side with the bend towards the inside. *Caulk all taper hoppers on same side and apply to both sides of holes.*
3. Align first taper hopper sheet section with one set of leg holes and assemble to inside of corrugated hoppers using #501442 hex bin bolts and #501441 flange nuts.

FIGURE 14

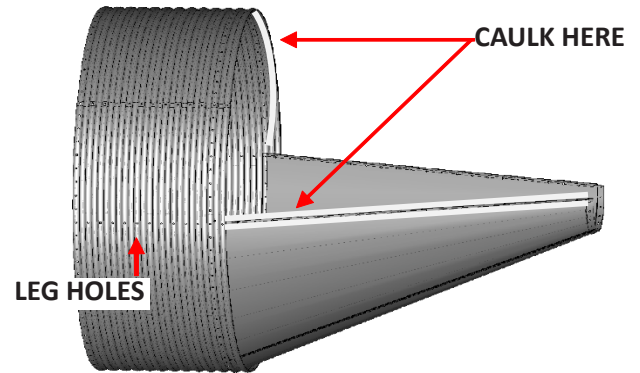

Keep bolt heads on outside of assembly.

- Leave holes that align with leg holes open until assembling legs to bin.
- Tighten nuts after each hopper sheet.

4. Place next taper hopper over previous one as shown in Figure 14 and align holes with drift pins. Assemble loosely to corrugated hoppers.
5. Align all holes and assemble as shown in drawing to the right, using #501440 Truss Head Bin Bolts and #501441 Flange Nuts. **Truss Head Bolts go on inside of hoppers.** Continue assembling all sections until the last two.

FIGURE 15

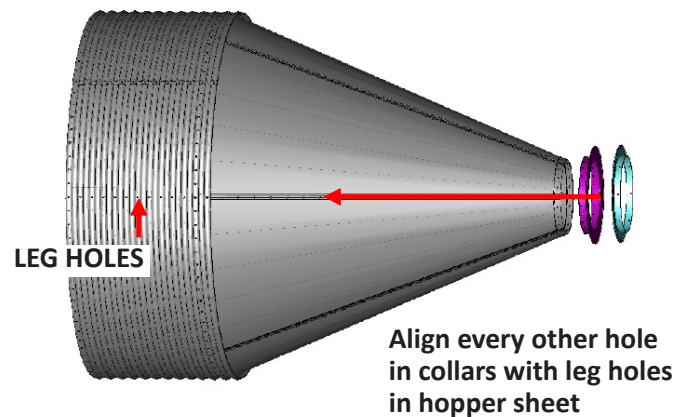

6. Caulk #507011 top collar on both sides of holes on out side of top flange. Place inside the end of the assembled hoppers. Align holes in collar so every other hole is aligned with a row of leg holes in corrugated hoppers. Assemble loosely with same hardware as above.
7. Finish assembling the final (2) sections and top collar. **Tighten all hardware.** Caulk #500260 Bottom Collar around opening on top side of collar. Assemble to #507011 Top Collar with (6) #012240 7/16" x 1" Hex Bolts, #010254 Lockwashers and #011116 Nuts using the six holes that do not align with legs.

FIGURE 16

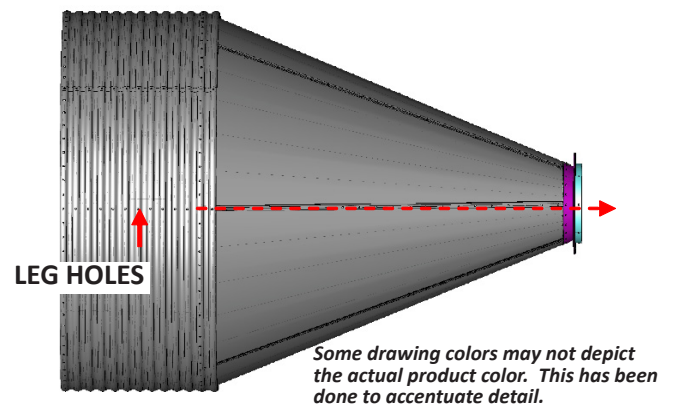

Roof Deck and Lid Collar Assembly

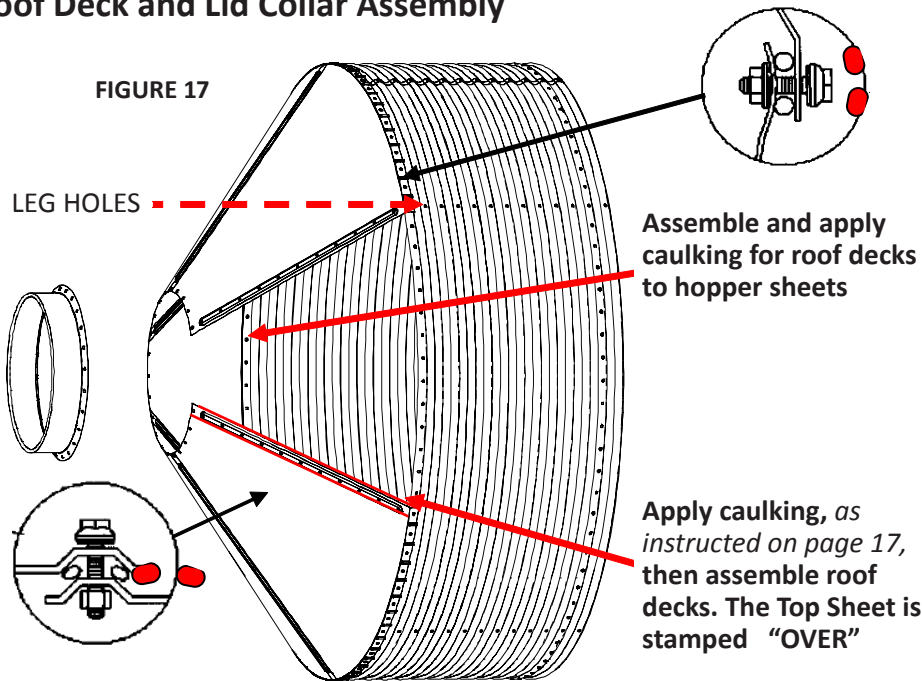

If you chose to perform a VERTICAL assembly, you should attach Bin Lifting Brackets as you attach roof deck sections. See page 26.

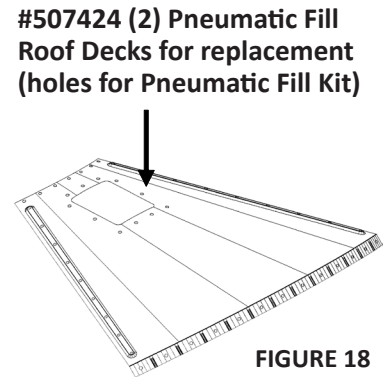

Before assembling roof deck you must decide where the lid opener and ladder will be located. In addition; when installing PNEUMATIC FILL BINS you must decide on the Roof Deck replacement location.

1. After deciding on proper layout, you need to begin caulking roof decks along both sides of bottom holes and holes along side marked "OVER".
2. Assemble roof decks over the top of corrugated hoppers starting with one end aligned with lid opener leg. Refer to drawings. Use 5/16" Hex Bin Bolts and Flange Nuts. **Keep bolt heads to the outside.**

The drawing below shows the recommended layout for locating the lid opener and ladder.

- Ladders should be located approximately 90 degrees from lid opener.
- Way-Back Opener does not need to align with leg.

FIGURE 19

Lid Opener Leg (Tru-Lok Add-On Option)

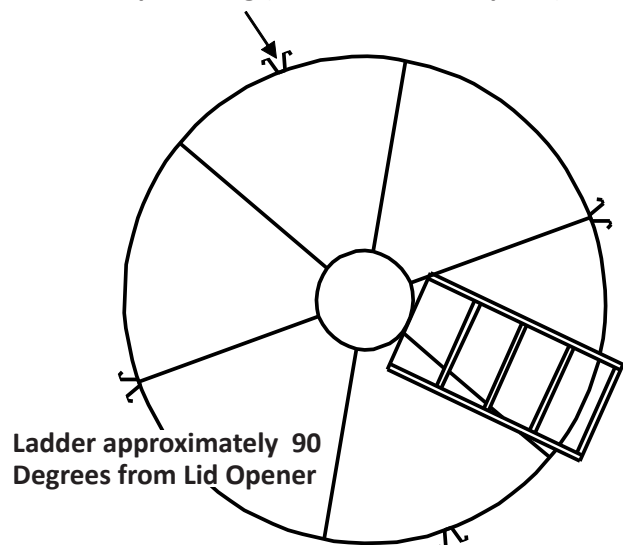

- Overlap sections as marked "over" or "under".
- Tighten nuts after each section.
- REPLACE (2) #507423 Roof Decks with (2) #507424 Roof Decks with holes (shown above in Figure 18.) when installing PNEUMATIC FILL BINS. Position Roof Decks across from each other. Refer to the Pneumatic Fill Quick Sheet more detailed Instruction.

3. Double caulk around holes on bottom of #507687 Lid Collar and position on roof decks. Refer to drawing above in Figure 17.
4. Tighten collar and roof decks secure with same hardware as above.



Leg and Tank Assembly

After you have finished assembling the tank, it is time to attach the bin legs.



- To assemble legs you will need someone inside the bin to push bolts thru holes.
- While someone is still in bin, you can assemble the ladder brackets as described on pages 22 and 23 to eliminate having to re-enter bin later.

1. The #507024 146" bin leg attaches to the (12) leg holes in the bottom ring as shown in Figure 20 to right. **The #507039 178" bin leg will require the bottom two rings or (24) holes.**
2. Align holes with Drift Pin from outside bin. Hand tighten #501442 Bin Bolts and #501441 Flange Nuts on all holes. Refer to Figure 20.
3. Roll the bin to assemble each leg until all the legs are complete. **Tighten all nuts secure.**
4. Before person exits bin, have them check for missing bolts by darkening bin and looking for light thru open holes.
5. After legs are secure, you can now assemble top and bottom Leg Base Plates to each leg. Use (3) #010664 3/8 x 1 Hex Bolts, (3) #010253 3/8" Lockwashers and (3) #011115 3/8" Nuts per leg. Refer to Figure 22 and 23 below. **Tighten nuts secure.**

FIGURE 20

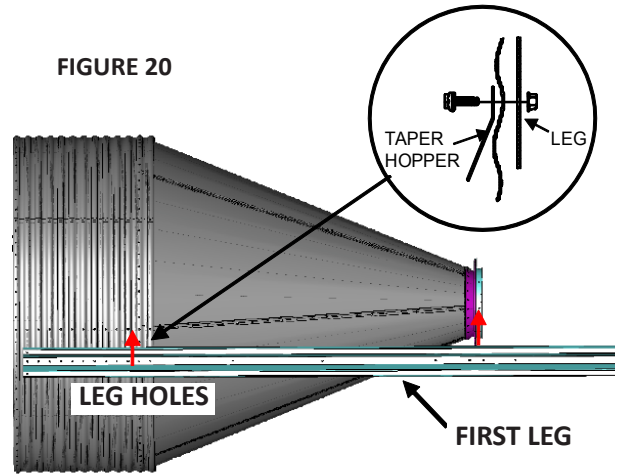

FIGURE 21

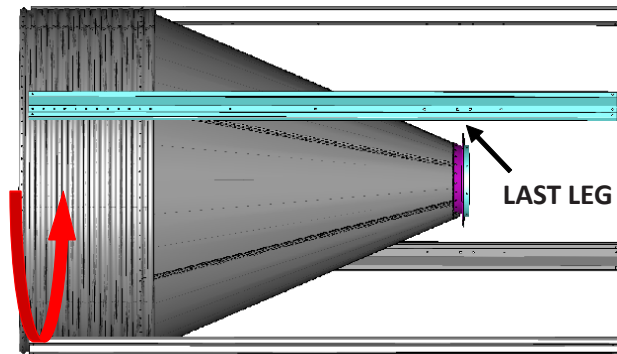

FIGURE 22

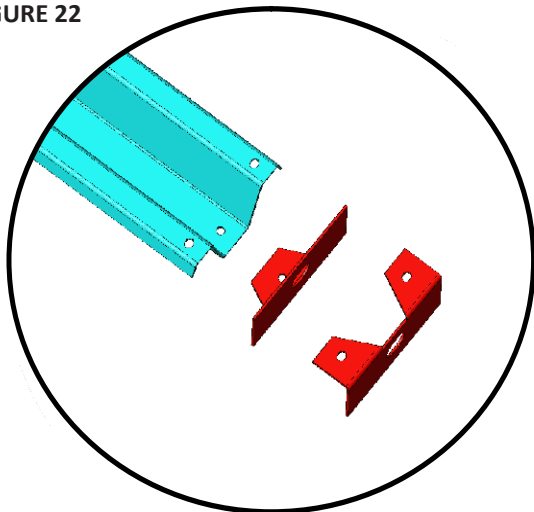
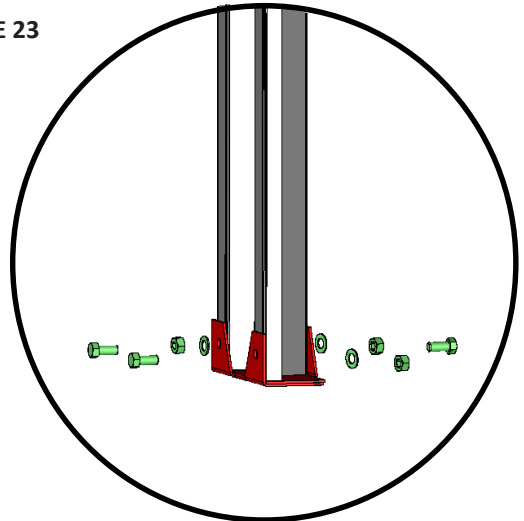
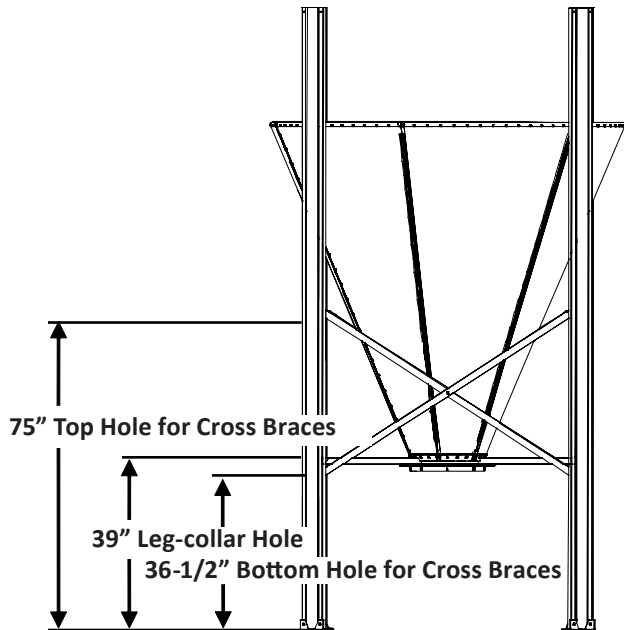

FIGURE 23



Leg and Brace Assembly

FIGURE 24



LEG BRACING DETAIL

FIGURE 25

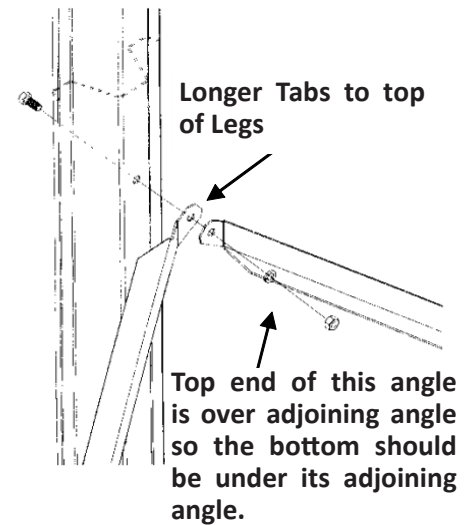

1. Assemble #507230 Front Cross Angle and #507231 Rear Cross Angle together in center with #012240 7/16" x 1" Hex Bolt, #010254 7/16" Lock-washer and #011116 Nut as shown in Figure 24 above.
2. Position between pair of legs using holes as shown in Figure 25 and fasten with same 7/16" hardware as above. Ends of angles with longer tabs go to the top of the legs. Alternate positioning of ends is recommended for best fit.

EXAMPLE: If top end of angle is over adjoining angle then bottom end of that angle should be under the adjoining angle) Repeat assembly until all cross braces are assembled. Do not tighten nuts until all bracing is finished.

3. Fasten #507232 Leg-Collar Brace between each leg and the top of collar with the same 7/16" hardware as rest of bracing. Use leg hole shown above and aligning hole in collar to assemble braces. **Brace must point to opposite leg or bin component failure may result.**
4. Tighten all hardware secure when bracing is completed.

BOTTOM VIEW WITH BRACING on 7 ft Bin

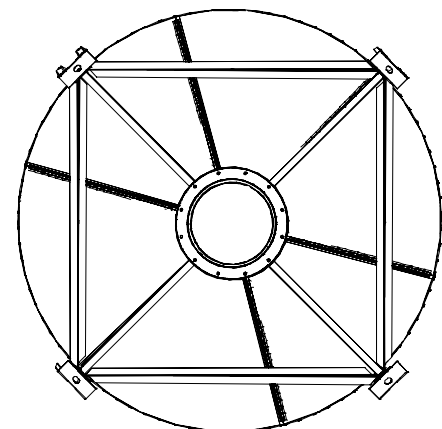

COLLAR BRACING DETAIL

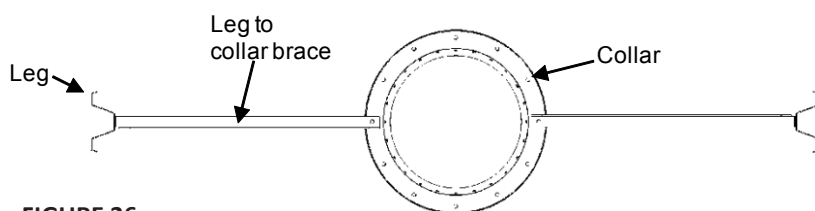

FIGURE 26

FIGURE 27



Roof Ladder Assembly



Before assembling the roof deck sections and lid collar make sure you have determined where the roof ladder should be located.

1. Remove the (2) bolts in lid collar that align with the holes in the #500278 Roof Ladder Standoff and assemble Standoff to lid collar with the same hardware.



The following part of this assembly requires someone inside bin and can be done previously at the same time you are assembling the legs.

2. Now find the (2) holes in the roof deck and hopper seam that align with the outside holes of the Ladder Standoff, (6 hole spread) as shown in Figure 28.
3. Remove the existing hardware and fasten (2) #500195 Top Ladder Brackets to bin with the same hardware, using the top hole in each bracket as shown in Figure 28.
4. Assemble (2) #507915 Roof Deck Ladder Rails and (4) #500030 Ladder Steps with #010643 5/16" X 3/4" Bolts and #012789 Locknuts. **Keep locknuts to inside of rails.** Refer to Figure 29 to right, to determine proper spacing for rails.

FIGURE 28

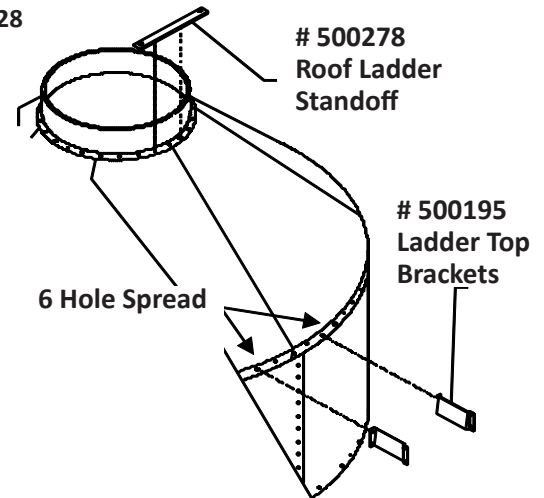

500030 Ladder Steps

FIGURE 29

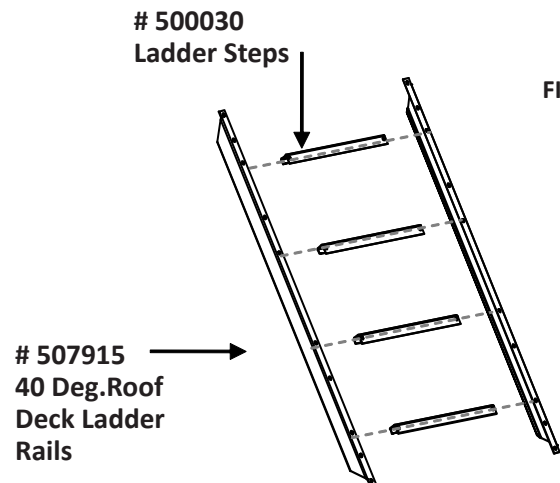
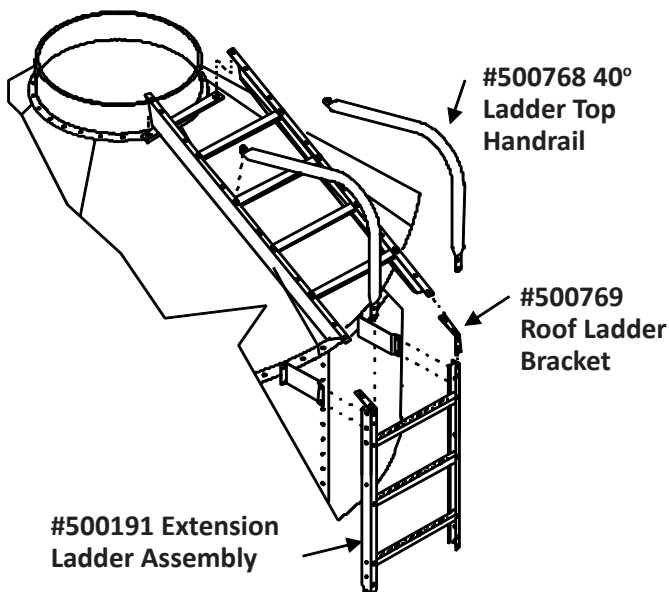

FIGURE 30



5. After Roof Ladder is assembled, fasten to Roof Standoff with (2) #010643 5/16" x 3/4" Hex Bolts and #012789 Locknuts. Get (1) #500191 Ladder Extension Assembly and fasten #500769 Roof Ladder Bracket to inside of top end of both rails and #500768 Handrail to outside of rails using same hardware as above.
6. Position ladder rails (either the Extension Ladder Assembly or the Basic Ladder Assembly rails) over top brackets and slide open end of Roof Ladder Brackets under roof ladder. Align the (2) holes in Top Brackets and Roof Ladder Brackets with the ladders and loosely assemble parts with hardware above. Assemble the top end of the (2) #500768 handrails with same hardware and tighten all nuts secure. All nuts should be to inside of ladders.

Side Ladder Assembly

In each corrugated hopper sheet seam you must attach (2) #500031 Ladder Brackets in alignment with the top brackets assembled previously.



This part of assembly requires someone inside the bin and can/could be done previously at same time you are assembling legs.

1. Remove the bin hardware in each hole that aligns with the top brackets and assemble (2) #500031 Ladder Brackets per hopper ring using the same hardware just removed.
2. Slip next Extension Ladder Assembly inside bottom of previous ladder and assemble to each other and adjacent Ladder Brackets with (4) #010643 5/16" x 3/4" Hex bolts and #012789 Locknuts.
Repeat until all ladder extensions are assembled.

FIGURE 31

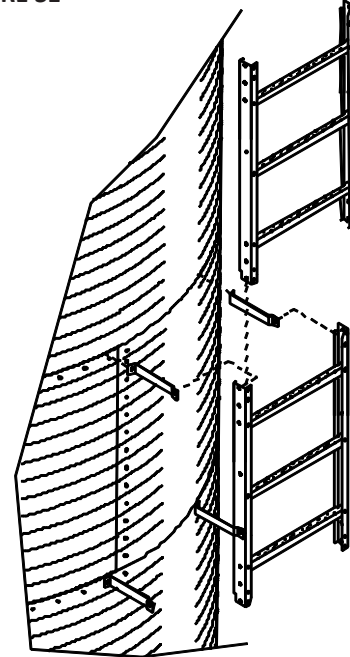

After all extension ladders are assembled -

3. Take #507034 Ladder Standoff Rail and assemble between legs below ladders using the bottom hole of each leg (approximately 21" from bottom of leg) and #501442 Bin Bolts and Flange Nuts.
4. Align (2) #500031 Ladder Brackets with Ladder Brackets above and fasten to Standoff Rail with #010643 Bolts and #012789 Locknuts.
5. Slide #500772 Basic Ladder Assembly under bottom rails of Extension Ladder and assemble to Extension Ladder and both Ladder Brackets on Standoff Rail using #010643 Bolts and #012789 Locknuts.
After ladder is assembled tighten all locknuts.

FIGURE 32

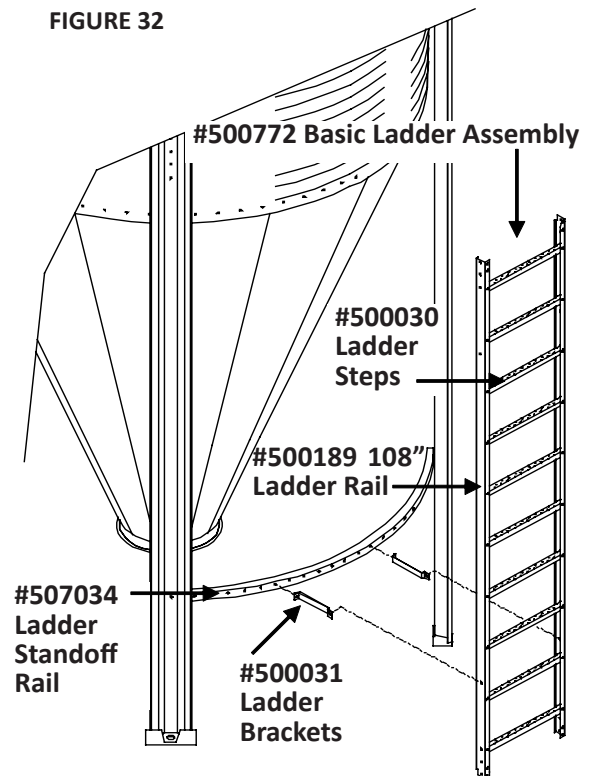

Make sure all locknuts are tightened securely before proceeding to next step. Do not over-torque locknuts.



Erecting the Bin

Before erecting your new bin be sure all parts are assembled properly and hardware tightened securely.

1. Peel protective paper off "VAL-CO™" decal before raising bin.
2. Cut 2" x 4" braces to 59-7/8" long and fasten between legs as shown below in Figure 33 Bottom End View.
3. Place 2" x 4" bracing between legs, as shown below in Figure 33, to provide extra support.
4. Raise the bin as shown in Figure 34 below. Be sure to use appropriate heavy equipment.



- Be sure to use proper strength heavy equipment such as; crane, truck with hydraulic lift bed or other.
- Level the legs, to assure stability, after the bin is raised.
- Leg shims #500249 are available.

FIGURE 33

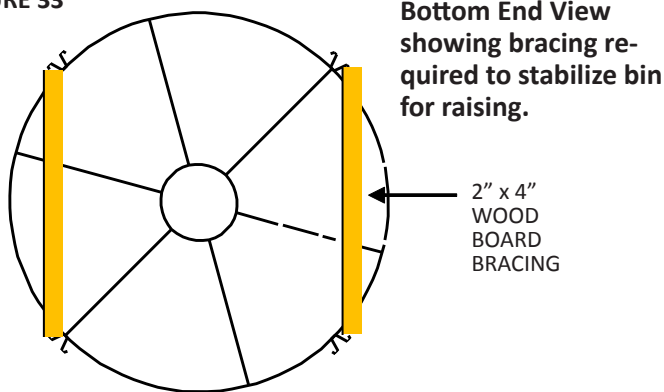

Raising the Bin - Using Sling/Cable Method

Val-Co recommended Bin Lifting Kit method is on next page.

FIGURE 34

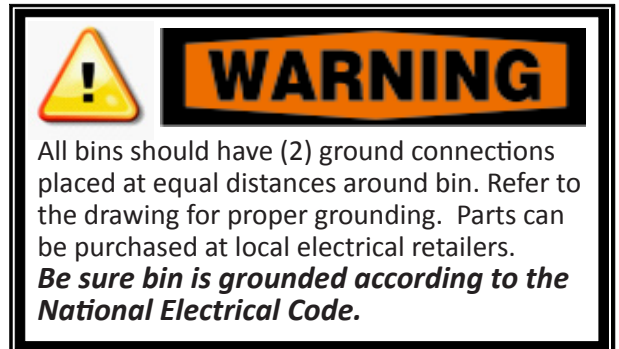
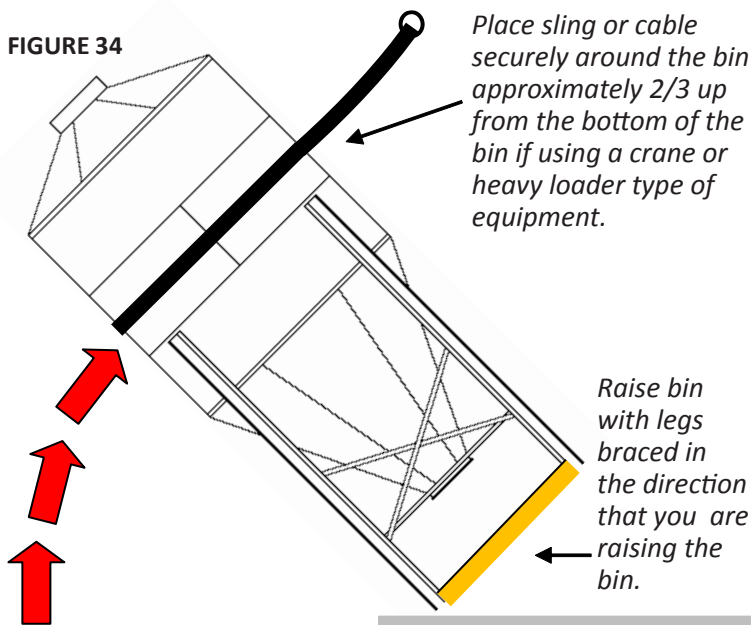

Bin Grounding Instructions

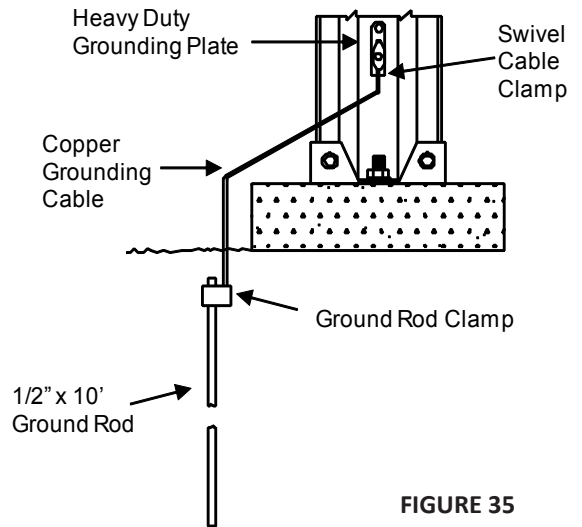
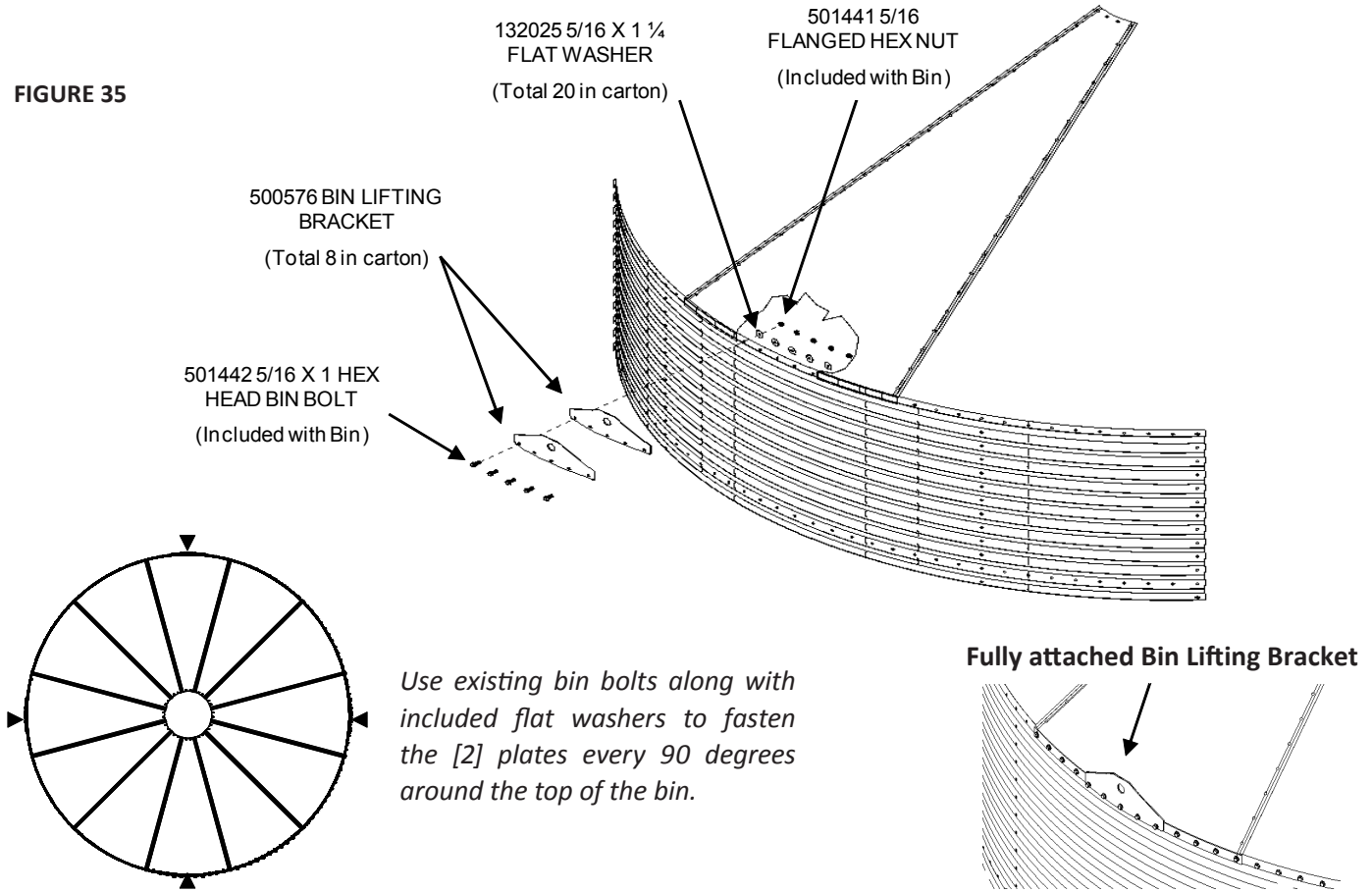

FIGURE 35



Bin Lifting Kit Assembly

FIGURE 35



Raising the Bin - Using Bin Lifting Kit method

Used ONLY in verticle assembly

When using the Bin Lifting Kit method, attach a chain to each bracket. Bring the 4 chains together and attach to a single chain/cable using the proper heavy equipment to lift.

FIGURE 36

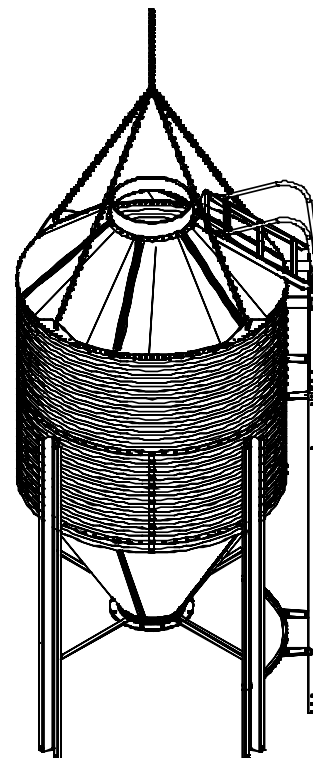

Be sure chains are **SECURE** before lifting!





Appendix 1- 7 Ft Feed Bin Parts List (Refer to page 14 and 15 for overview drawing of bin parts)



Check all parts with packing list included in the product carton or this list below before starting assembly. Report any shortages immediately to your supplier.

Save all cartons until the bin is completed.

PART #	DESCRIPTION	QTY PNEUMATIC FILL	QTY WAYBACK LID
1 Ring Feed Bin		507741	507W41
507046	18 ga. Main Hopper - Plain With Drip Edge	1	1
507047	18 ga. Main Hopper - Decal With Drip Edge	1	1
507024	Galv. Leg - 146" (1-4R)	4	4
507230	Front Cross Tie Angle	4	4
507231	Rear Cross Tie Angle	4	4
507232	Leg-Collar Brace Angle	4	4
507423	Roof Deck Section (40° Roof)	4	6
507424	Roof Deck Section - Pneumatic Fill 40 °	2	0
507018	Taper Hopper Section 16"	6	6
507160	Basic Hardware Carton	1	1
507171	Collar Carton	1	1
500650	Way-Back Lid Carton	0	1
500790	40° Pneumatic Fill Kit Lid Carton	1	0
2 Ring Feed Bin		507742	507W42
507046	18 ga. Main Hopper - Plain With Drip Edge	2	2
507007	20 ga. Extension Hopper - Plain	1	1
507008	20 ga. Extension Hopper - Decal	1	1
507024	Galv. Leg - 146" (1-4R)	4	4
507230	Front Cross Tie Angle	4	4
507231	Rear Cross Tie Angle	4	4
507232	Leg-Collar Brace Angle	4	4
507423	Roof Deck Section (40° Roof)	4	6
507424	Pneumatic Fill Roof Deck Sect 40° w/Hole	2	0
507018	Taper Hopper Section 16"	6	6
507160	Basic Hardware Carton	1	1
507072	Extension Hardware Carton	1	1
507171	Collar Carton	1	1
500650	Way-Back Lid Carton	0	1
500790	40° Pneumatic Fill Kit Lid Carton	1	0



Appendix 1 - 7 Ft Feed Bin Parts List Continued

PART #	DESCRIPTION	QTY PNEUMATIC FILL	QTY WAYBACK LID
3 Ring Feed Bin		507743	507W43
507046	18 ga. Main Hopper - Plain With Drip Edge	2	2
507007	20 ga. Extension Hopper - Plain	3	3
507008	20 ga. Extension Hopper - Decal	1	1
507024	Galv. Leg - 146" (1-4R)	4	4
507230	Front Cross Tie Angle	4	4
507231	Rear Cross Tie Angle	4	4
507232	Leg-Collar Brace Angle	4	4
507423	Roof Deck Section (40° Roof)	4	6
507424	Roof Deck Section - Pneumatic Fill 40°	2	0
507018	Taper Hopper Section 16"	6	6
507160	Basic Hardware Carton	1	1
507072	Extension Hardware Carton	2	2
507171	Collar Carton	1	1
500650	Way-Back Lid Carton	0	1
500790	40° Pneumatic Fill Kit Lid Carton	1	0
4 Ring Feed Bin		507744	507W44
507046	18 ga. Main Hopper - Plain With Drip Edge	2	2
507007	20 ga. Extension Hopper - Plain	5	5
507008	20 ga. Extension Hopper - Decal	1	1
507024	Galv. Leg - 146" (1-4R)	4	4
507230	Front Cross Tie Angle	4	4
507231	Rear Cross Tie Angle	4	4
507232	Leg-Collar Brace Angle	4	4
507423	Roof Deck Section (40° Roof)	4	6
507424	Roof Deck Section - Pneumatic Fill 40°	2	0
507018	Taper Hopper Section 16"	6	6
507160	Basic Hardware Carton	1	1
507072	Extension Hardware Carton	3	3
507171	Collar Carton	1	1
500650	Way-Back Lid Carton	0	1
500790	40° Pneumatic Fill Kit Lid Carton	1	0



Appendix 1 - 7 Ft Feed Bin Parts List Continued

PART #	DESCRIPTION	QTY PNEUMATIC FILL	QTY WAYBACK LID
5 Ring Feed Bin		507745	507W45
507046	18 ga. Main Hopper - Plain With Drip Edge	2	2
507016	18 ga. Main Hopper - Plain	2	2
507007	20 ga. Extension Hopper - Plain	5	5
507008	20 ga. Extension Hopper - Decal	1	1
507039	Galv. Leg - 178" (5-6R)	4	4
507232	Leg-Collar Brace Angle	4	4
507073	Brace Tie Bundle (6 Braces Per Bundle)	1	1
507074	"X" Brace Bundle (6 Braces Per Bundle)	1	1
509167	Special Bracing Hardware Bag	1	1
507423	Roof Deck Section (40° Roof)	4	6
507424	Roof Deck Section - Pneumatic Fill 40°	2	0
507018	Taper Hopper Section 16"	6	6
507049	TH Reinf. Angle	6	6
507160	Basic Hardware Carton	1	1
509163	178" Leg Hardware Carton	1	1
507072	Extension Hardware Carton	4	4
507171	Collar Carton	1	1
500650	Way-Back Lid Carton	0	1
500790	40° Pneumatic Fill Kit Lid Carton	1	0



Appendix 1 - 7 Ft Feed Bin Parts List Continued

PART #	DESCRIPTION	QTY PNEUMATIC FILL	QTY WAYBACK LID
6 Ring Feed Bin		507746	507W46
507046	18 ga. Main Hopper - Plain With Drip Edge	2	2
507016	18 ga. Main Hopper - Plain	2	2
507007	20 ga. Extension Hopper - Plain	7	7
507008	20 ga. Extension Hopper - Decal	1	1
507039	Galv. Leg - 178" (5-6R)	4	4
507232	Leg-Collar Brace Angle	4	4
507073	Brace Tie Bundle (6 Braces Per Bundle)	1	1
507074	"X" Brace Bundle (6 Braces Per Bundle)	1	1
509167	Special Bracing Hardware Bag	1	1
507423	Roof Deck Section (40° Roof)	4	6
507424	Roof Deck Section - Pneumatic Fill 40°	2	0
507018	Taper Hopper Section 16"	6	6
507049	TH Reinf. Angle	6	6
507160	Basic Hardware Carton	1	1
509163	178" Leg Hardware Carton	1	1
507072	Extension Hardware Carton	5	5
507171	Collar Carton	1	1
500650	Way-Back Lid Carton	0	1
500790	40° Pneumatic Fill Kit Lid Carton	1	0



Appendix 2 - 7 Ft Feed Bin Accessories Parts List

PART #	DESCRIPTION
Bin Accessories	
500220	Anchor Bolt Kit for 6' and 7' Diameter Bins
507515	7' Taper Hopper Access Panel
501397	Roof Vent Kit - 7' Bin
502003	Peek Thru Window
500578	Bin Lifting Bracket Kit
507090	2.02 ton 20 ga. Extension Ring With Hardware - 7' Bin
500191	Ladder Extension for 6', 7', 9' and 12' Bins
507250	7' Bin Taper Hopper Repair Kit
501190	Manual Slide Valve Assembly - 16"
501997	Optional Rack & Pinion Crank Attachment for 501190 Slide Valve
500621	Taper Hopper Slide Valve
500471	16" Boot Slide Valve Assy (plastic upper boot transition required for installation)
Bin 16" Opening Attachments	
500475	30° Upper Boot Transition - Green
500485	Straight Upper Boot Transition - Green
500575	30° Upper Boot Transition - Clear
500585	Straight Upper Boot Transition - Clear
700010	Straight Double Upper Boot Transition (Accommodates 2 Lower Boots)
501190	Manual Slide Valve
501997	Rack & Pinion with Crank
500471	Boot Slide Valve - Single Slide
500374	Boot Slide Valve - Split Slide

Appendix 3 - Bin 16" Opening Attachments

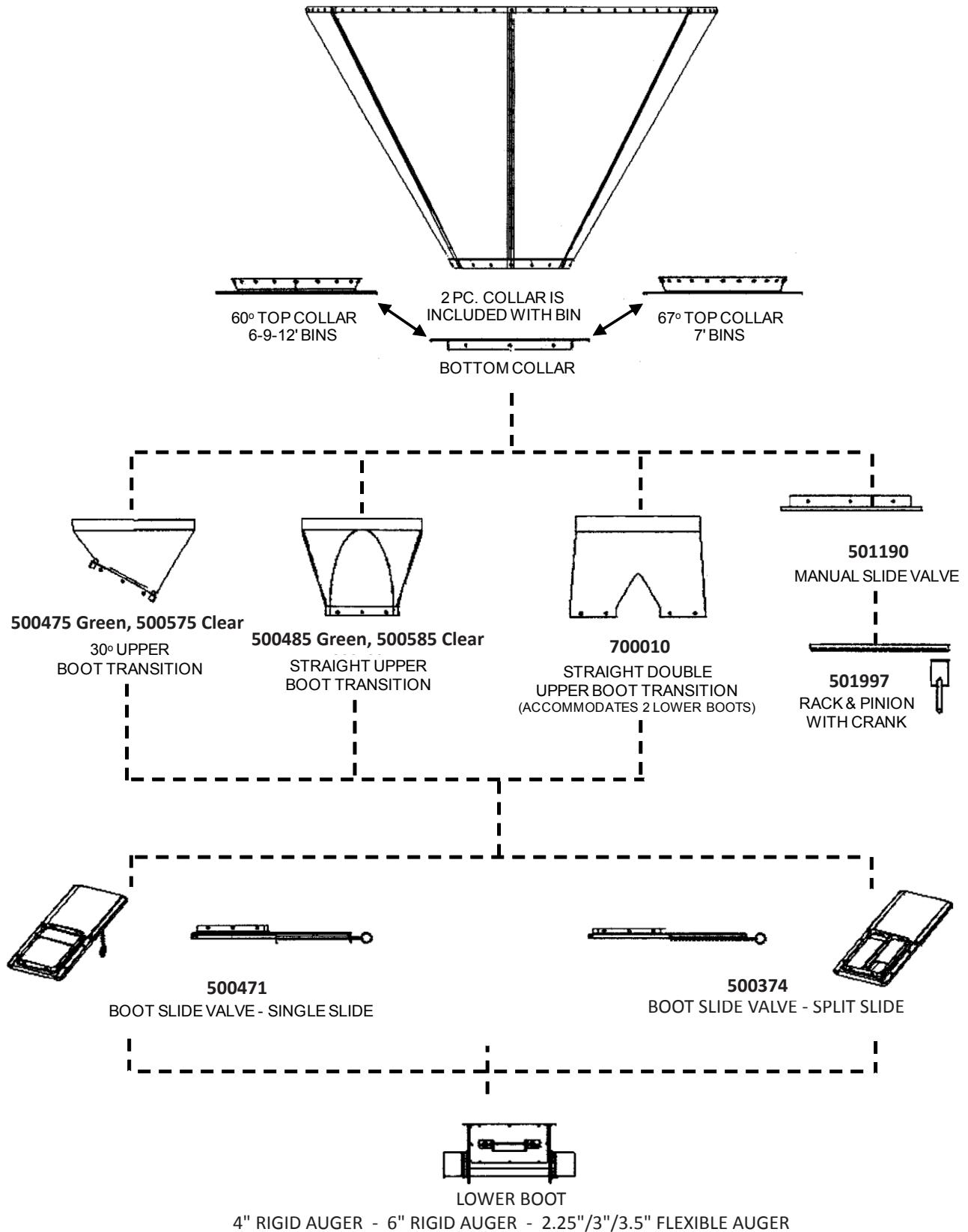



Appendix 4 - Auger Length Needed

4" and 6' Rigid Auger

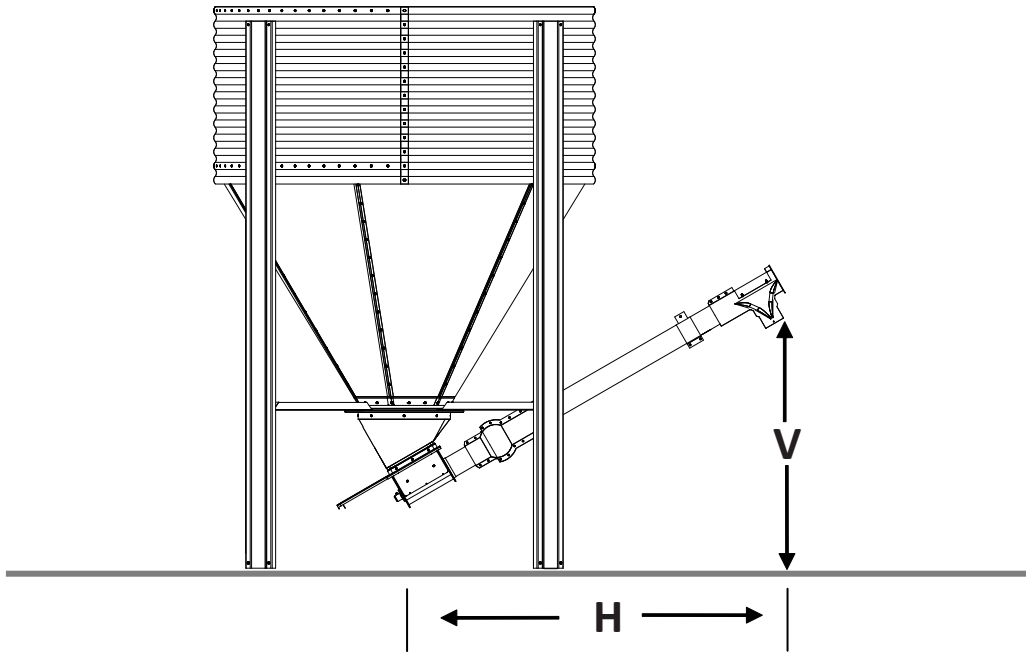

ANGLE OF ELEVATION	AUGER LENGTH													
	5 FT.		8 FT.		11 FT.		12 FT.		16 FT.		20 FT.		21 FT.	
	H	V	H	V	H	V	H	V	H	V	H	V	H	V
15° ANGLE	6' 4"	2' 8"	9' 2"	3' 6"	12' 1"	4' 3"	13' 1"	4' 6"	16' 11"	5' 7"	20' 10"	6' 7"	21' 9"	6' 10"
30° ANGLE	5' 11"	3' 11"	8' 7"	5' 5"	11' 2"	6' 11"	12' 0"	7' 5"	15' 6"	9' 5"	18' 11"	11' 5"	19' 10"	11' 11"
45° ANGLE	5' 4"	5' 0"	7' 5"	7' 2"	9' 7"	9' 3"	10' 3"	10' 0"	13' 1"	12' 10"	15' 11"	15' 8"	16' 7"	16' 4"

Parts List for Augers and Boots are not included in this manual. To order parts please contact your VALCO™ representative. Installation instructions are included with the Auger and Boot packing lists.

Appendix 5- Way-Back Lid Overview

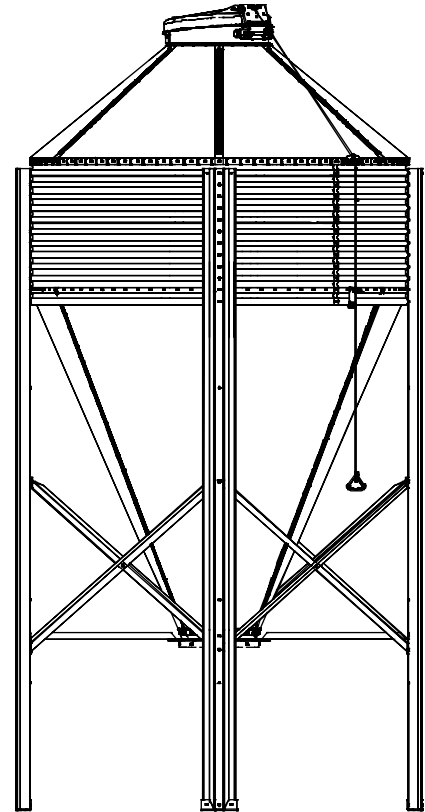
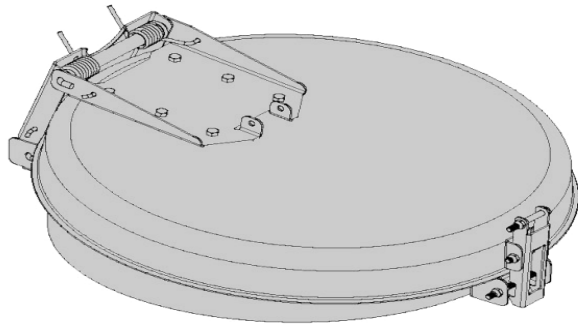

Lid Closed

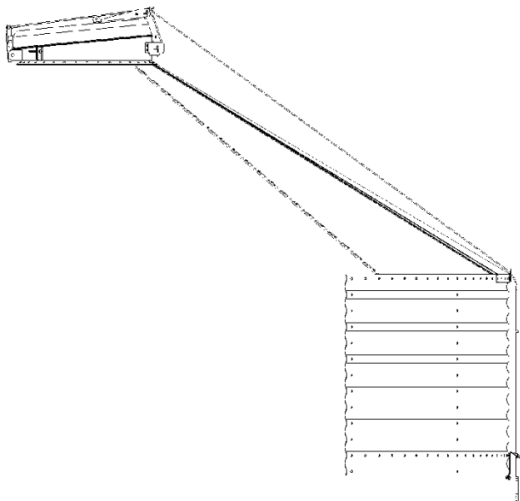

Lid Fully Open

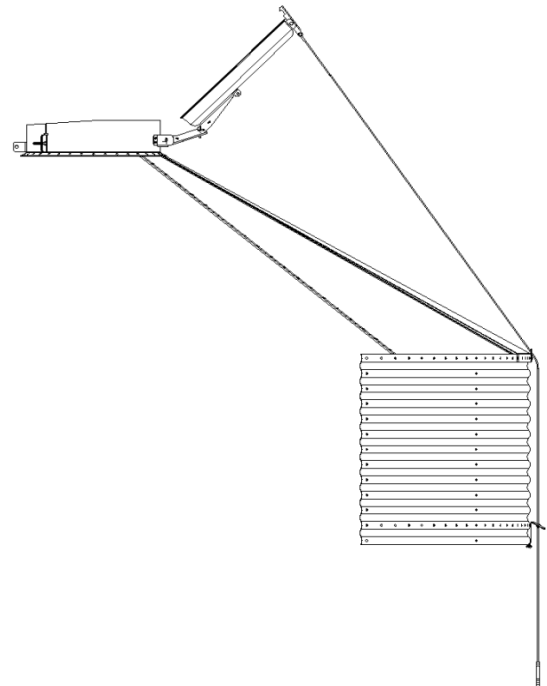



Appendix 6 - Exploded Way-Back Lid Assembly drawing (500650)

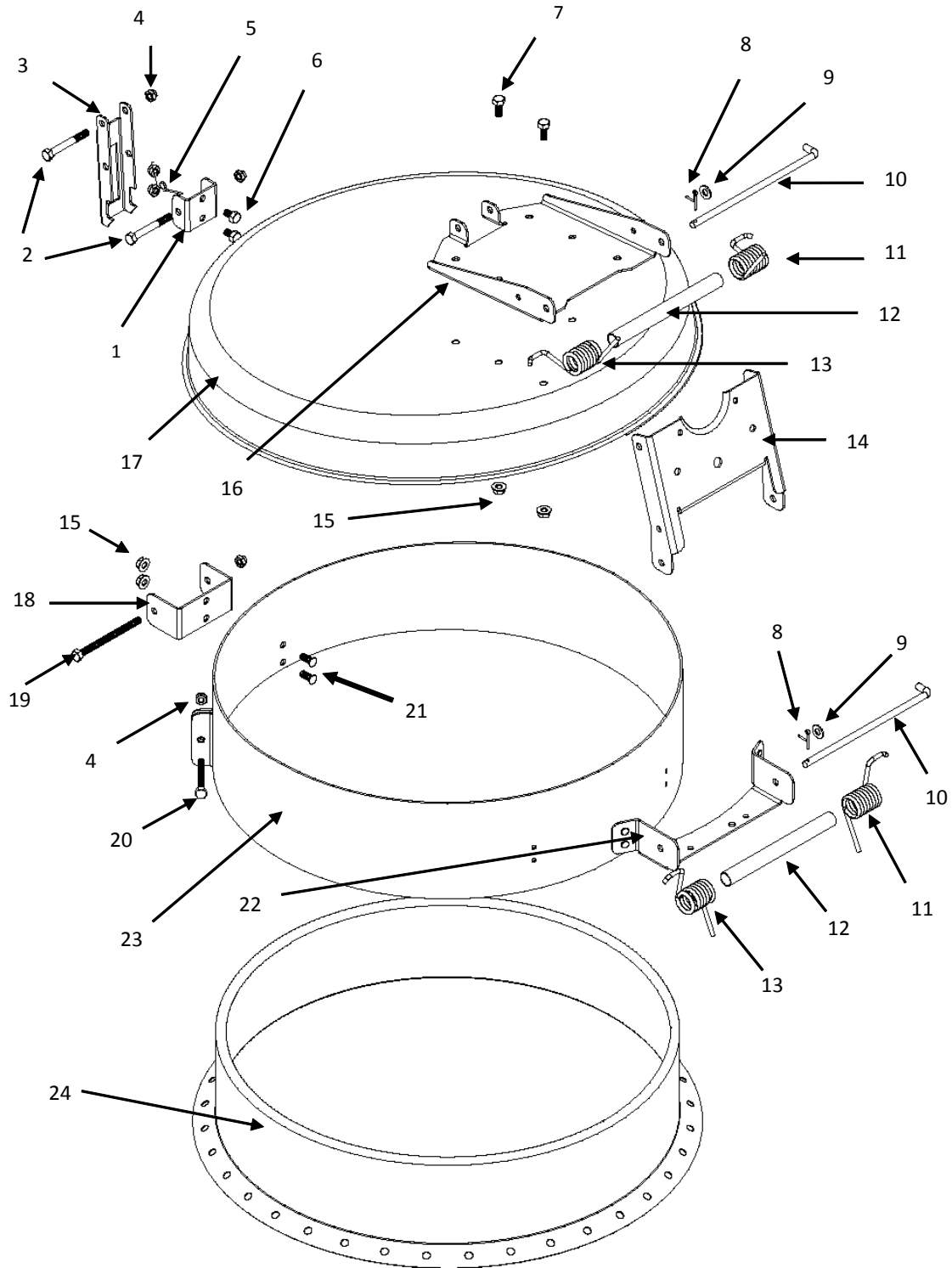



Appendix 7 - Way-Back Lid Parts List

When ordered as Replacement Parts the Quantities will vary

KEY #	PART #	DESCRIPTION	QTY
500650 – WayBack Lid Assembly (Pre-Assembled)			
1	500659	Lid Locking Bracket	1
2	010652	5/16" X 2-½" Hex Bolt	2
3	500660	Unlocking Arm	1
4	012789	5/16" Locknut	6
5	500662	Locking Spring	1
6	010640	5/16" X ½" Hex Bolt	2
7	010643	5/16" X ¾" Hex Bolts	6
8	012660	Cotter Pin	2
9	010426	5/16" Washer	2
10	500685	Hinge Rod	2
11	500482	Right Hand Spring	2
12	500658	Spring Spacer	2
13	500492	Left Hand Spring	2
14	500654	Collar – Hinge Bracket	1
15	500441	5/16" Flange Nut	8
16	500655	Top Hinge Bracket	1
17	500686	Bin Lid	1
18	500661	Collar Lock Bracket	1
20	010656	5/16" X 4" Bolt	1
21	012780	5/16" X 3/4" Thread Stud	2
21	010651	5/16" X 2-½" Bolt	1
22	500653	Bottom Hinge Bracket	1
23	500652	Lid Locking Collar	1
24	X sizes	Lid Collar (not included in kit)	1



Appendix 8 - Way-Back Lid Cord Containment Bracket and Retainer Parts List

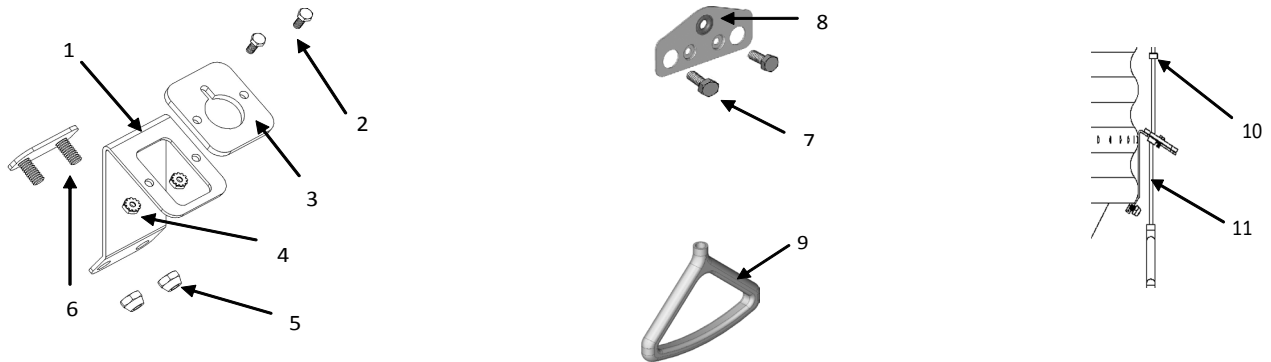

When ordered as Replacement Parts the Quantities will vary

KEY #	PART #	DESCRIPTION	QTY
#500679 - Cord Containment Bracket Assembly Parts List			
1	500691	Cord Retainer	1
2	012795	#10-24 x 1/2" Un-Slotted Hex Screw	2
3	500664	Plastic Cord Guide	1
4	012408	#10-24 Kep Locknut	2
5	012789	5/16"-18 NYLOCK nut	2
6	500671	Cord Containment Clamp	1
7	012425	1/4" X 3/4" Self Drilling Screws	2
8	500688	Rope Retainer	1
9	500666	Cord Handle	1
10	500669	Cord Locking Collar	2
11	500668	Cord	1

Appendix 9 - Tru-Lok Add-On Lid Opener and Ladder Overview

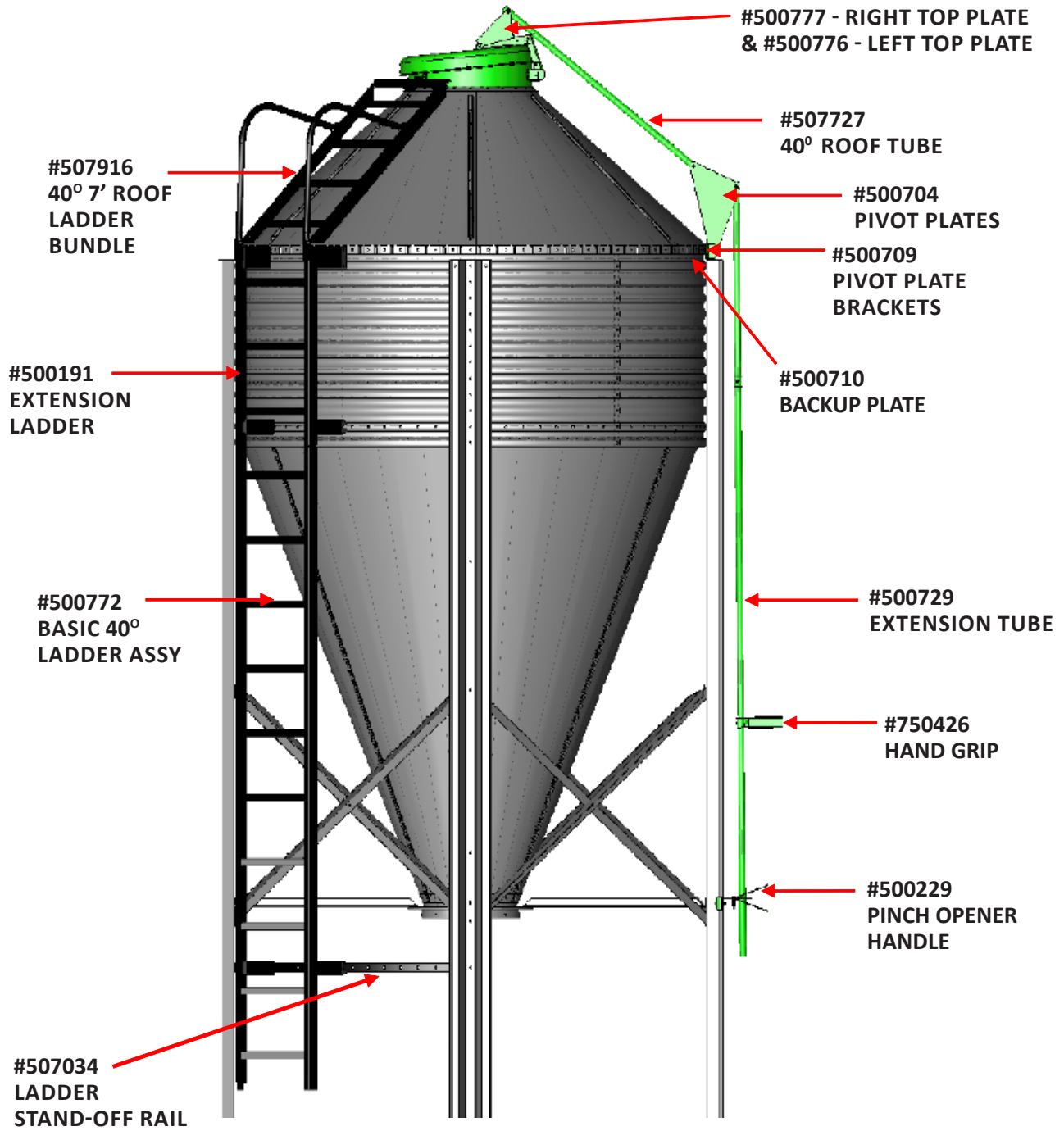



Appendix 10 - Tru-Lok Add-On Parts List

PART #	DESCRIPTION	QTY
OPTIONAL - Tru-Lok Add-On (Available for all 7 ft Feed Bins)		
500775	Tru-Lok Accessory Carton	1
507727	Tru-Lok 40° Roof Tube - 7'	1
500226	Tru-Lok Basic Tube	1
500729	Tru-Lok Extension Tube (Quantity will equal the number of Rings)	1-6
500728	Tru-Lok Tube Guide (Available for 3-6 Ring only)	1
Tru-Lok Add-On - REPLACEMENT PARTS (Quantities will vary)		
500777	Right Top Plate	-
500776	Left Top Plate	-
507727	40° Roof Tube	-
500704	Pivot Plates	-
500709	Pivot Plate Bracket	-
500710	Backup Plate	-
500257	Pinch Handle Assembly	-
500229	Pinch Opener Handle	-
500228	Pinch Opener Mtg Bracket	-
010126	1/2" Medium Load Spring	-
500719	Handle Bracket Clip	-
010625	1/4-20 x 2 Hex Bolt	-
012793	1/4-20 Nylock Nut	-
500230	Handle	-
750426	Hand Grip	-
010643	5/16-18 x 3/4" Hex Bolt	-
011434	1/4-20 x 1 Carriage Bolt	-
010943	1/4-20 Wing Nut	-
010649	5/16" Hex Bolt	-
012789	5/16" Locknut	-
501442	5/16" x 1" Flanged Hex Bin Bolt	-
501441	5/16" Flange Nut	-

Appendix 10 - Tru-Lok Add-On Parts Drawing (Option)

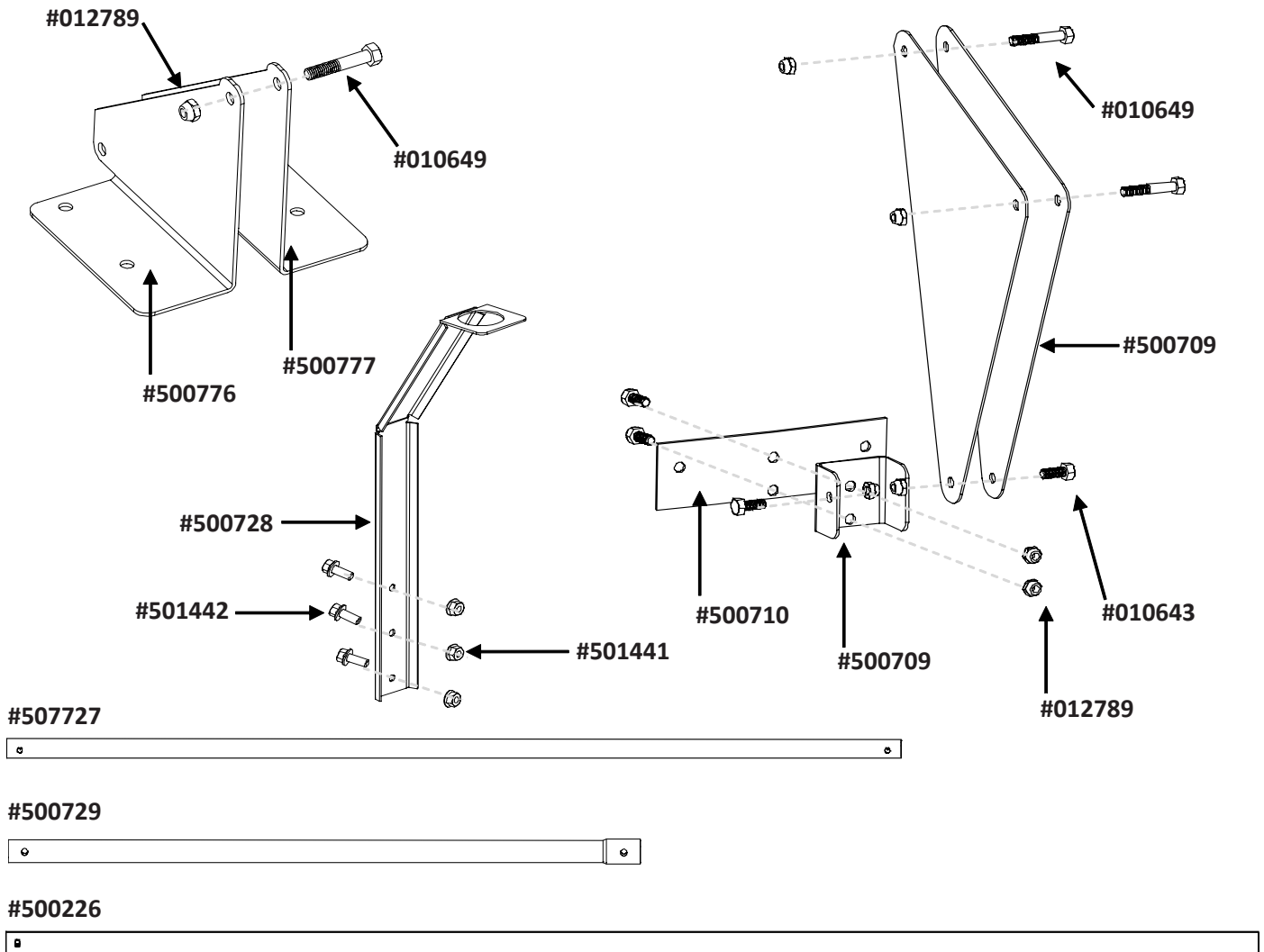

It should be noted that the Basic Tube has NO holes for connections on the bottom end and the Extension Tube has a belled end to fit over, for connection, to the Basic Tube or other Extension Tubes.

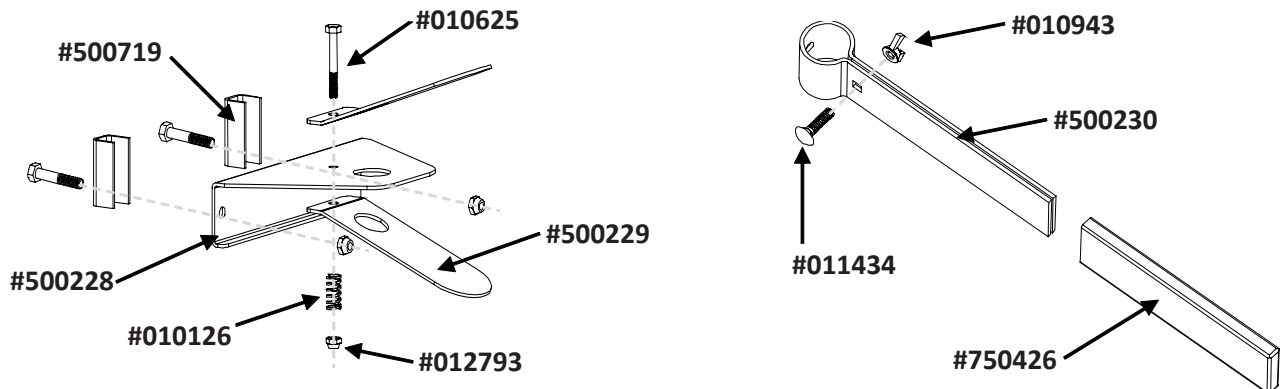



Appendix 11 - LadderParts Drawing and Parts List

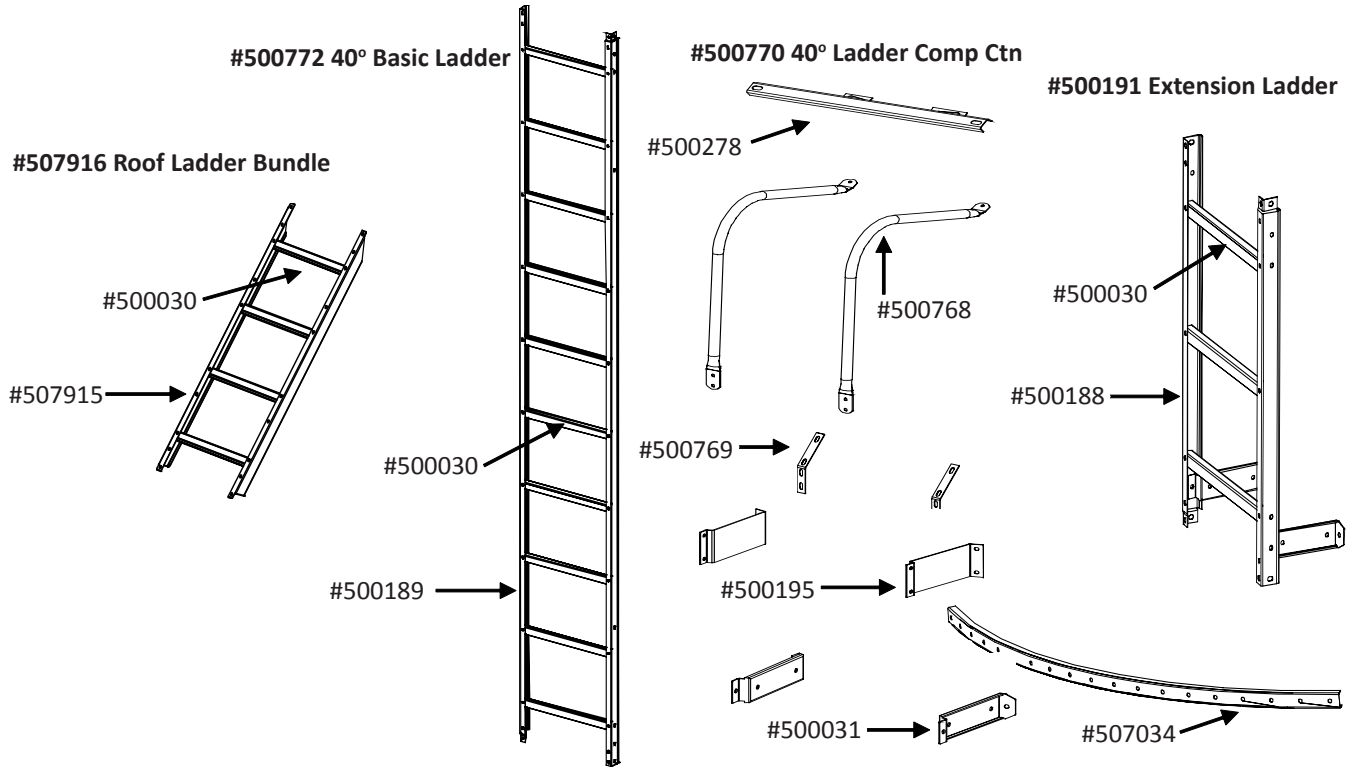

PART #	DESCRIPTION	QTY
OPTIONAL - Ladder Assemblies 507921,507922,507923,507924,507925, 507926		
500772	Basic 40° Ladder Assy	1
500191	Extension Ladder (36") (Quantity will equal the number of Rings)	1-6
507034	Ladder Stand-Off Rail	1
507916	40° 7' Roof Ladder Bundle	1
Ladder - REPLACEMENT PARTS (Quantities will vary)		
010643	5/16-18 X 3/4" Hex Bolt	-
012789	5/16-18 Nylock Nut	-
500030	Ladder Step	-
500188	Ext Ladder Rail (36")	-
500189	Ladder Rail (108")	2
500199	Ext Ladder Hardware Bag	1
500770	40 DEG Ladder Comp Ctn	1
500031	Ladder Attachment Bracket	-
500195	Ladder Top Bracket	-
500278	Roof Ladder Standoff	1
500287	Ladder Hdwe Bag	-
507915	7' x 40° Roof Ladder Angle	-
500768	40° Ladder Top Handrail	2
500769	40° Roof Ladder Bracket	2
509915	40° Roof Ladder Rail	2

Appendix 12- Ladder Cage Parts List (Option)

Optional Cage on 6 Ring Bin



PART #	DESCRIPTION	QTY
OPTIONAL - Ladder Cage		
500924	LADDER CAGE KIT - 6x2, 7x1, 9x1 (1 Ring Bin)	1
500925	LADDER CAGE KIT - 6x3, 7x2, 9x2, 12x1	1
500926	LADDER CAGE KIT - 6x4, 7x3, 9x3, 12x2	1
500927	LADDER CAGE KIT - 7x4, 9x4, 12x3	1
500928	LADDER CAGE KIT - 7x5, 9x5, 12x4	1
500929	LADDER CAGE KIT - 7x6, 9x6, 12x5	1
Ladder Cage - REPLACEMENT PARTS (Quantities will vary)		
500901	LC Eave Extension	-
500902	LC Support to Roof LDDR	-
500903	LC Support to Bin	-
500904	LC Support - Short Vert	-
500905	LC Support - Basic Vert	-
500906	LC Support - Ext Vert	-
500907	LC Support - Hoop/Rail	-
500908	LC Half Hoop Ext	-
500909	LC Bottom Hoop Ext	-
500910	LC Support - Formed Vert	-
500914	LC Basic Top Hardware Bag	-
500915	LC Basic Bottom Hardware Bag	-
500916	LC Ext Hardware Bag	-
500920	LC Support - O/S Roof Ladder	-



Appendix 13 - Pneumatic Fill Overview and Parts List (Option)

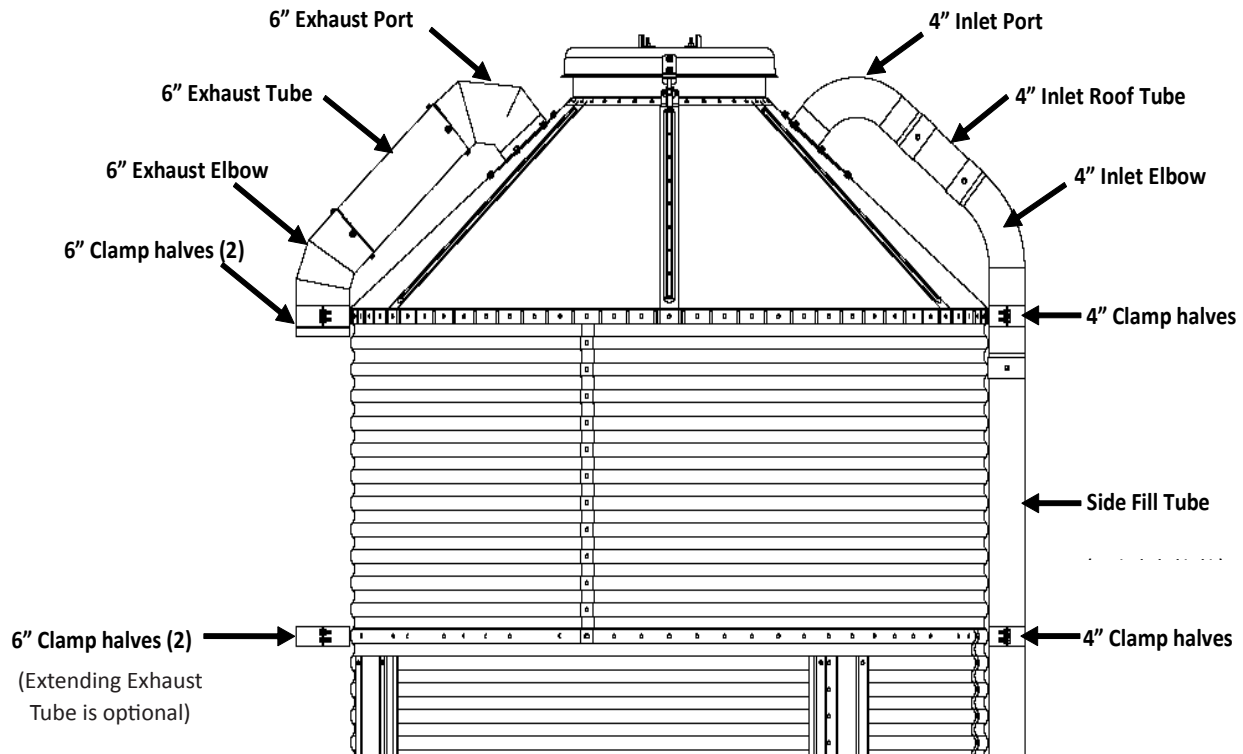

When ordered as Replacement Parts the Quantities will vary

PART #	DESCRIPTION	QTY
OPTIONAL - Pneumatic Fill Parts		
500534	Caulking (50' roll)	1
500740	4" Narrow Clamp (half)	6
500743	6" Exhaust Port (elbow) w/plate	1
500744	6" x 24" galv. Duct elbow	1
500751	6" Exhaust clamp (half)	6
500786	4" inlet port w/plate	1
500788	51 Degree Elbow (drilled)	1
500942	Pneumatic Fill Hardware bag	1
509425	6" x 39.87" Exhaust Tube	1
509918	4" x 32.82" Inlet (roof) Tube	1
704441	4" x 4' Galvanized Side Fill Tube (Available for 6 ring only)	1
704412	4" x 11' Galvanized Side Fill Tube (Available for 1-2 Ring only)	1
704413	4" x 15' Galvanized Side Fill Tube (Available for 3 Ring only)	1
704414	4" x 19' Galvanized Side Fill Tube (Available for 4-6 Ring only)	1
704287	4" Tube Joiner With Hardware (Available for 6 Ring only)	1



Appendix 14 - Customer Service

My dealer's name:

_____ Street / PO Box _____

_____ City _____

How to contact my dealer:

_____ State / Province _____

_____ Zip / Postal _____

Customer Service

210 E. Main Street
P. O. Box 117
Coldwater, OH 45828
800.998.2526

_____ Phone _____

_____ Fax _____

_____ E-mail _____

_____ Web site _____



North America:

Phone: 800.99VALCO (800.998.2526)

Fax: 419.678.2200

ail: sales@val-co.com

International:

Phone: (+1) 419.678.8731

Fax: (+1) 419.678.2200

Email: intl.sales@val-co.com